

15/ITC/2055577-LND/ZK

STATE OF TEXAS §

COUNTY OF KENDALL §

**LANDSCAPE DESIGN STANDARDS AND GUIDELINES  
OF THE ESPERANZA COMMUNITY ASSOCIATION, INC. FOR  
THE VILLAGE OF BRAVADA (A PART OF ESPERANZA PHASE 2F)**

*September 2021*

**Document reference.** Reference is hereby made to that certain Declaration of Covenants, Conditions, and Restrictions for the Village of Bravada (A Part of Esperanza Phase 2F) September 2021, filed as Document No. 2021 – 361494 (117 pages) in the Official Public Records of Kendall County, Texas (together with all amendments and supplemental documents thereto, the “**Declaration**”).

WHEREAS the Declaration provides that owners of lots subject to the Declaration are automatically made members of Esperanza Community Association, Inc. (the “**Association**”);

WHEREAS the Association is in the Declarant Control Period as defined in the Declaration, and the Declarant, pursuant to the Declaration and Bylaws of the association, may adopt and amend rules from time to time; and

THEREFORE, the Landscape Design Standards and Guidelines (“**Rules**”) attached as Exhibit “A” have been, and by these presents are, **ADOPTED** and **APPROVED**.

LOOKOUT DEVELOPMENT GROUP, L.P.  
a Texas limited partnership

By: The Lookout Group, Inc., a Texas corporation,  
its General Partner

By:   
James D. Plasek, Vice President

STATE OF TEXAS §

COUNTY OF WILLIAMSON §

This instrument was acknowledged before me on the 16th day of September, 2021, by James D. Plasek, Vice President of The Lookout Group, Inc., a Texas corporation, General Partner of Lookout Development Group, L.P., a Texas limited partnership, in the capacity herein stated.

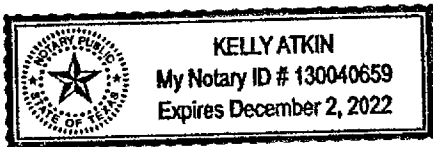

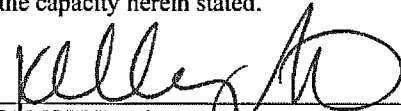
  
NOTARY PUBLIC IN AND FOR  
THE STATE OF TEXAS

My commission expires: 12-2-22

Printed Name: Kelly Atkin

**EXHIBIT A: RULES**  
**EXHIBIT B: TABLE OF LANDSCAPE DESIGN STANDARDS AND GUIDELINES**

# **EXHIBIT A**

## **RULES**



# Esperanza

BOERNE ★ TEXAS  
PHASE 2F

VILLAGE OF BRAVADA



# TABLE OF CONTENTS

Introduction .....	1
Authority .....	4
General Character and Intent .....	7
Yard Site Plans .....	10
Landscape Requirements .....	13
Streetscape Improvements .....	31
Fences and Walls .....	34
Architectural Elements and External Decorations .....	48

# INTRODUCTION





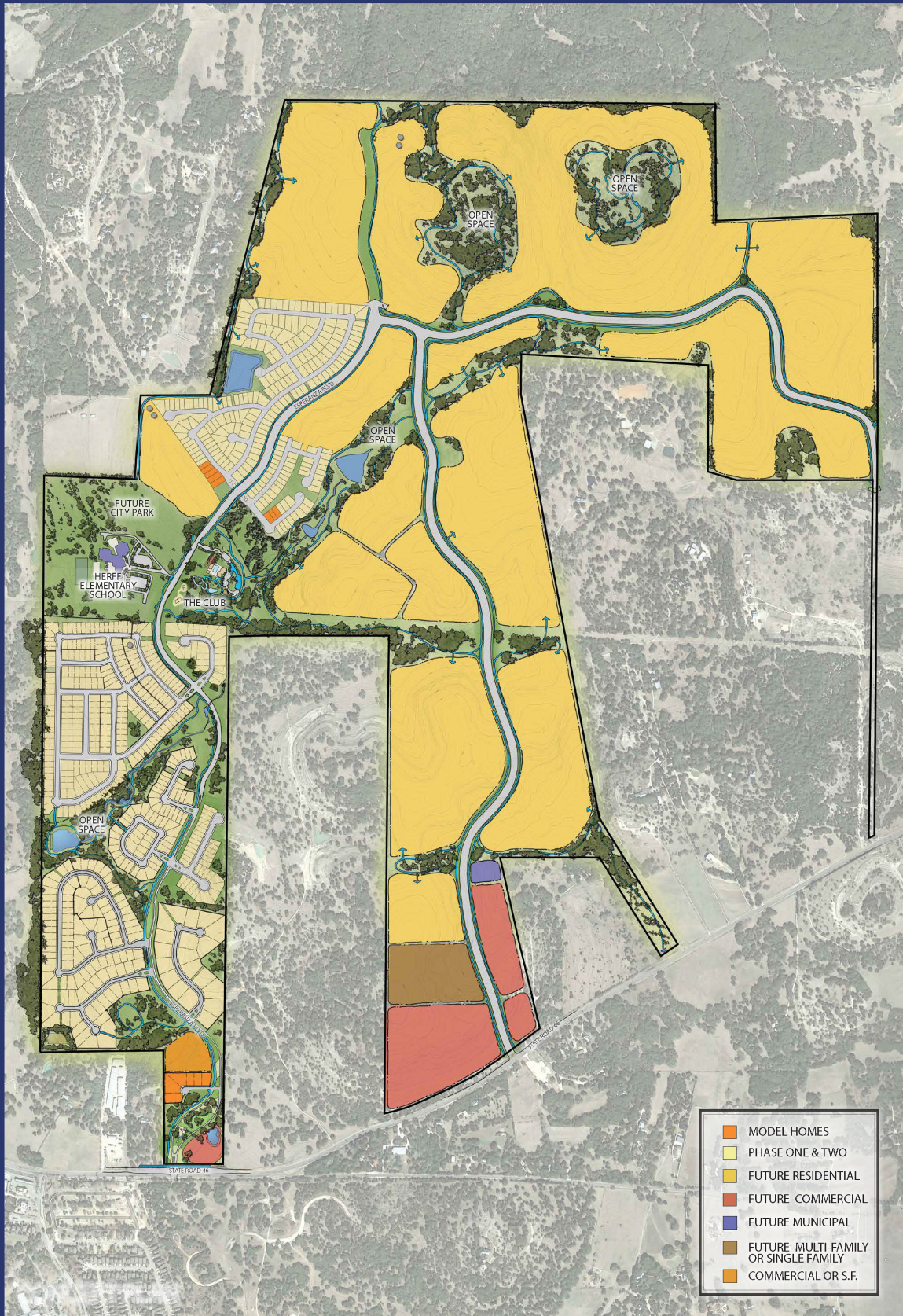

## CONCEPT PLAN





Esperanza is a master planned community in harmony with its magnificent hill country setting. To that end, the focus of these Guidelines are to distinguish Esperanza as an environmentally friendly community through the preservation of existing tree canopies and natural features, the selection of native and adaptive plant materials, as well as the use of sustainable practices in planting and irrigation.

Additionally, these Guidelines address privacy and comfort within the development by paying special attention to lighting and fencing standards. The Guidelines for lighting promote a dark sky community while ensuring nighttime livability, while fencing ensures sufficient privacy for individual lots that will not diminish the natural setting of Esperanza.

The information in these Guidelines is presented as a convenient reference to assist land owners, architects, engineers, landscape architects and designers in the most advantageous adaptation of the Esperanza protective covenants and design guidelines for landscape design and construction. These Guidelines have been carefully formulated to ensure an attractive environment for all of its users and to safeguard all future landscape improvements, making sure that they are complimentary to the architecture and environment of the community.





# AUTHORITY

Unless the context otherwise specifies or requires, the words and phrases used herein shall have the same meanings specified in the Declaration of Covenants, Conditions, and Restrictions For Esperanza (CC&Rs). In addition, the Landscape Design Standards and Guidelines (Guidelines) contain language that reflects the following meanings:

“Shall” or “Must” refers to a building standard and means that conformance is mandatory. These standards are consistent with the Development Agreement, CC&Rs and the vision of the Developer. Builders or homeowners that deviate from these landscape requirements must submit plans for Architecture Control Committee (ACC) review and approval prior to installation.

“Should” or “Highly encouraged” refers to a building guideline and is intended to be a recommendation to builders and owners. Conformance will be strongly encouraged by the ACC and the HOA through its enforcement powers.

It is strongly recommended that a thorough review be made of the CC&Rs as well as the existing development regulations and zoning requirements for the City of Boerne which are applicable to Esperanza including those set forth in the Development Agreement between the City of Boerne and the prior owner of Esperanza, MA Boerne Partners, LP (“MA Boerne”) regarding Esperanza, with an effective date of February 12, 2008 (the “Development Agreement”), which Development Agreement is evidenced in the real property records of Kendall County, Texas by a Memorandum of Development Agreement recorded as Document No. 00274382 in Volume 1361, Page 834 in the real property records of Kendall County, Texas, as revised from time to time. Wherever there is a conflict, the most stringent applications shall apply. This will ensure that builders and owners in Esperanza have a thorough understanding of the scope and extent of the overall community development and how it relates to residential construction.

The master developer has the express right and privilege to amend these Guidelines at any time until its jurisdiction is surrendered or terminated pursuant to the CC&Rs. There is no limitation on the scope of amendments to either increase or decrease the restrictiveness of the requirements previously imposed. Any amendments shall apply to construction and modifications commenced after the date of such amendment only and shall not require modifications or removal of structures previously approved once the approved construction has commenced.

These Guidelines govern all property subject to the CC&Rs. Unless otherwise specified in these Guidelines, all construction projects, design issues and structures erected on a Lot must conform to these guidelines. If a project deviates from these Guidelines, written ACC approval is required before construction activity begins. While an Owner may remodel, paint or redecorate the interior of his or her home without approval, any exterior improvement (alteration, decoration, construction, landscaping or hardscape visible from adjoining properties, the public right of way or community open space) is subject to approval from the ACC.

These Guidelines are intended to provide parameters for design quality and community appearance, but they are not all inclusive, nor do they supersede the authority of existing development regulations and zoning restrictions for the City of Boerne that are applicable to the Property as defined in the Development Agreement.

# GENERAL CHARACTER AND INTENT



The general intent of these Guidelines is to provide requirements as a framework for site improvements through landscape plantings. The object is to create an orderly planned landscape utilizing the minimum standards set in these Guidelines.

The plant materials presented in this document are considered to be appropriate for Esperanza. These plant materials have been chosen for their natural or adaptable qualities, their function in the landscape, drought tolerance, deer resistance and their availability in commercial nurseries. In the interest of sustainability, the landscape should blend with, rather than contrast with the existing vegetation. Natural or existing oaks, cedar elms and other trees shall be preserved and maintained as much as possible.

Plantings should be an interesting blend of plant materials that provide various color and texture throughout the building site. Informal, natural groupings are suitable; long linear hedges and large expanses of single plant species are not permissible.

Planting beds are to be curvilinear with the shrubs massed in tiers. Smaller shrubs and ground cover are to be placed in the front of the bed. Larger shrubs shall be placed in the rear of the bed. Groupings of shrubs of the same species should be used as these provide a substantial look. Planting shrubs along foundation in straight lines at a constant distance from the foundation should be avoided. Widths of the beds should vary. A single row of foundation planting is discouraged.

A variety of plant types and colors should be distributed among the lots to avoid monotony and redundancy within the streetscape. Adjacent lots should not have identical planting material selection and bed layout.

Plant species in landscape beds shall consist of 40% evergreen plant material selected from the approved plant list. No more than 50 percent of the required trees and shrubs shall be of the same species.

All plantings should be planted with the appropriate topsoil, additives and fertilizer mixtures. Prior to installing any sod or plants, the appropriate imported topsoil must





be installed to a depth of at least 4 inches. The use of only on-site soil is not allowed.

Landscape materials shall be hardy and disease resistant, and require low maintenance and minimum water such that once established, irrigation may be reduced or eliminated.

Depth of planting beds should be at least eight-feet (8') from the house.

No bare ground is acceptable. Mulch all planting beds, except for Planter Strips, with 3" deep shredded hardwood mulch. Planter Strips require ground cover using river rock (a minimum of 3 inches), Texas Orange River Rock or equivalent. However, turf grass may be used as ground cover in the side yard planter strip on corner lots only. If turf grass is used as ground cover in the side yard planter strip on a corner lot, a minimum of 3" river rock must be used as ground cover in the planting bed. White or light colored rock is not allowed. The use of rock as ground cover in any area other than Planter Strips is not allowed without written consent from the ACC Reviewer in their sole discretion. Specimen boulders are permitted when used sparingly.

Large trees and shrubs should be planted no closer to the foundation than five-feet (5') beyond the drip line of a mature plant.

Mulch bed areas and groundcover is acceptable only below dense tree canopies in an effort to minimize water usage. However, mulch bed areas and groundcover should not constitute more than 20% of the landscape planting for that lot. Additionally, areas that receive less than six hours of sunlight should be planted with shrubs and groundcover instead of turf.

All turf grass shall be Zoysia or Bermuda solid sod. St. Augustine turf grass is not permitted.

Planted shade trees are to be 2-inch (2") caliper minimum, measured twelve inches (12") above the base of the tree. Ornamental trees are to be a minimum of 6 feet (6') in height and have a full canopy. Planting of these trees in planting beds with shrubs and ground covers is encouraged, especially on corners.

Newly planted trees in lawn areas are required to have a round, mulched tree well that is a minimum diameter of three feet (3') for the first year after planting.

# YARD SITE PLANS



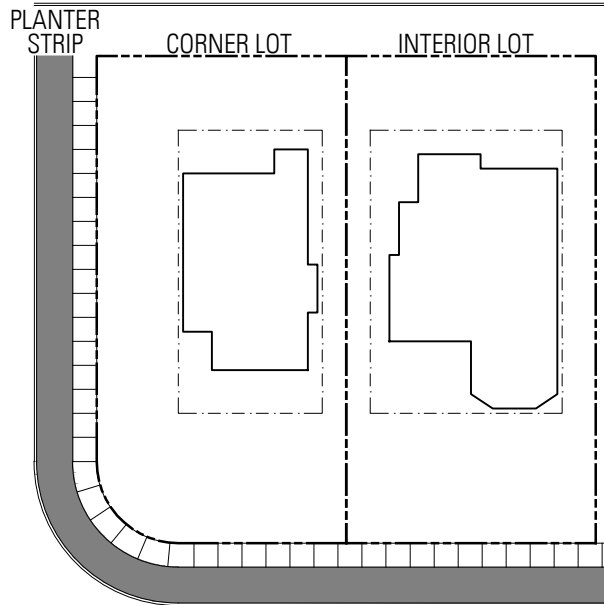
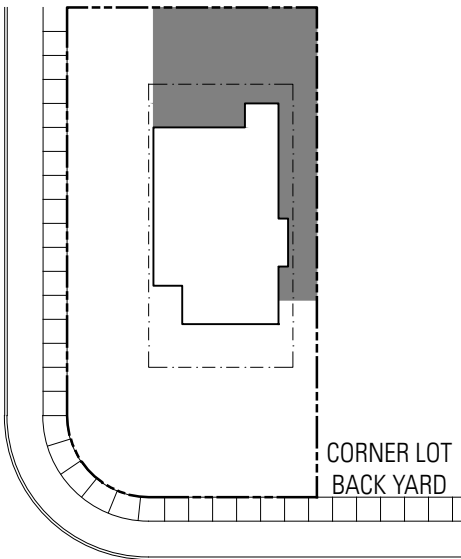
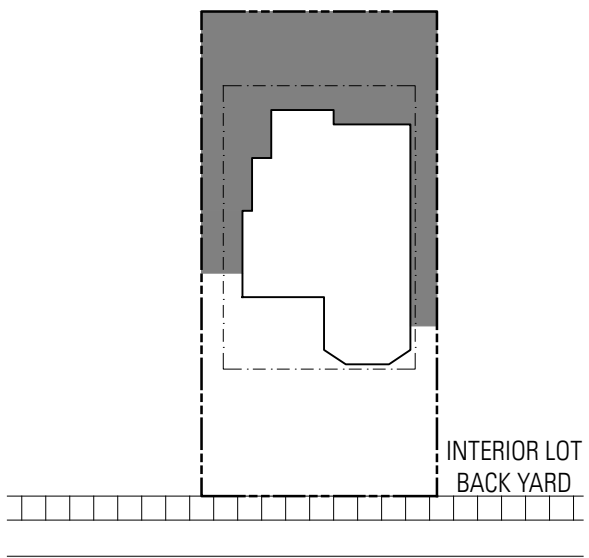
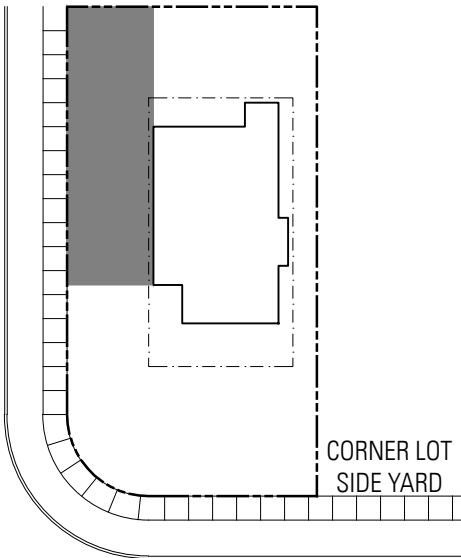
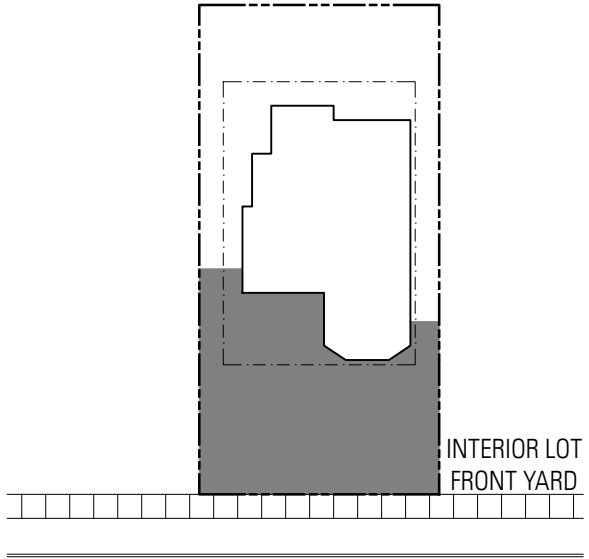
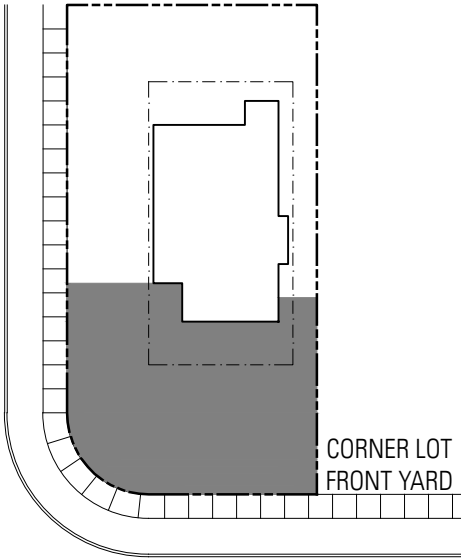



The front yard of an interior lot shall be defined as the area between side lot lines from the front house façade and fence to the front property line. Refer to graphic on this page.

The front yard of a corner lot shall be defined as the area between side lot lines from the front of the house, front facing fence and a line projected parallel from the front most dominant corner of the house, (excluding small projected porches and overhangs) to the side front property line. Refer to graphic on this page.

The side yard of a corner lot shall be defined as the area on the side of the house, front of garage, and street side yard fence to the property line from the front yard setback to the rear property line. Refer to graphic on this page.

Planter Strips are defined as the area between the back of curb to the sidewalk. All Planter Strips must be landscaped using material as indicated in the Landscape Requirements Chapter. Corner lots will include both a Front Yard Planter Strip and a Street Side Yard Planter Strip. In this case, both Planter Strips must be landscaped.

Shade trees should be container grown. They are to have a minimum two inch (2") caliper measured twelve inches (12") above the base of the tree. Ornamental trees should be container grown. They are to be a minimum of six feet (6') in height and have a full canopy. Ornamental trees shall be planted a minimum of 2'-0" behind the front property line and centered on the lot. When two or more shade trees are installed, they shall be spaced equally apart on the lot, if possible.

All yards shall be landscaped with a minimum combination of trees, shrubs, ground covers and grass. A minimum number of trees shall be planted in the front yard of each lot. Refer to diagrams and tables in the Landscape Requirements Chapter for the minimum number of trees and shrubs required. Existing trees can be used to meet the minimum requirements as long as the existing trees are in the Approved Plant List contained herein.

# LANDSCAPE REQUIREMENTS



## Minimum Requirement

Builders are responsible for the landscaping of all areas of their property and the planter strips adjacent to their property, in accordance with landscape standards defined in these guidelines. In order to preserve adequate sight lines for motorists, only rock, ground cover, and low growing shrubs (shrubs that will not exceed 36 inches in height at maturity) may be planted in the planter strip, refer to the Streetscape Improvements Chapter of these guidelines. Installation of all landscaping, including materials and workmanship, must comply with current industry standards. Landscape requirements in this section must be completed prior to the builder closing on the sale of the home to the home buyer.

- Residential lots must be landscaped using the ACC Approved Plant List containing plant and materials approved per these Landscape Design Standards and Guidelines and the CC&Rs.
- All plant materials, including trees, shrubs, ornamental grasses, ground cover, vines, and succulents/cacti shall be selected from the ACC Approved Plant List as amended from time to time. Priority will be given to native ecologically noninvasive plant materials.
- Landscape plans cannot deviate from the CC&Rs, these Guidelines and the applicable City standards unless they are reviewed and approved in advance, in writing, by the ACC. Landscape and irrigation plans submitted for review must include all plant material, lighting, landscape construction and underground irrigation systems to be installed.
- Landscape treatments shall not interfere with sight line requirements at street or driveway intersections.
- All landscape plant materials shall comply with American Association of Nurserymen (AAN) standards.
- Planted shade trees shall be provided in a size equal to a two inch (2") caliper minimum measured twelve inches (12") above the base of the tree.
- Ornamental trees are to be a minimum of 6' in height and have a full canopy.
- Shrubs shall be provided in a minimum size equivalent to the requirements of (5) five, (3) three and one (1) gallon container stock.
- Ornamental grasses, shrubs, vines, succulents/cacti, shade plants and ground cover shall be provided in a minimum size equivalent to the requirements of five (5), three (3) and one (1) gallon container stock.
- A minimum of three inches (3") of mulch shall be installed under trees and in all shrub and bed areas, unless approved river rock is used as ground cover (where allowed by this document).
- Landscaped areas not covered with plant materials or river rock shall be covered with mulch composed of organic materials only directly under dense tree canopies. A landscaping plan that utilizes more than 20% mulch as a predominant element is not acceptable.
- Above ground utility connections and HVAC units visible from the street or adjacent properties must be screened with approved plants. Screening plant material must be at least twenty-four inches (24") tall at installation with a mature height sufficient to cover the item the plants are screening.
- Buildings, structures and walls must be approved in writing by the ACC prior to the initiation of the construction of a wall.
- Planter Strips are required to utilize river rock as ground cover. River rock must be 3" minimum -Texas Orange River Rock or equivalent. However, turf grass may be used as ground cover in the side yard planter strip on corner lots only. If turf grass is used as ground cover in the side yard planter strip on a corner lot, a minimum of 3" river rock must be used as ground cover in the planting bed
- The following landscaping requirements must be installed by the builder in accordance with these guidelines and the CC&R's.

1. An irrigation system in accordance with the requirements of these Guidelines and Section 3.51 of the CC&Rs.
2. For the entire yard (including planter strips, front, rear and side yards), all areas to be covered with lawn grass must be planted using Zoysia or Bermuda sod only; grass seeding, including hydro mulch, is not allowed. The builder is to sod all disturbed areas that are not replanted with approved container plants to prevent erosion and the encroachment of unwanted or noxious weed species.
3. Buffalo grass, including seeding (hydro mulch or other means of broadcasting grass seed) and sod, is only allowed for greenbelts and common areas.
4. Completed landscaped yards must contain approved plants and materials only.
5. Installed landscaping shall be properly maintained at all times.
6. Refer to the drawings and tables in this chapter for the required shade trees, ornamental trees, shrubs, ornamental grasses or groundcover requirements by residential lot size.
7. Existing trees can be used to meet the required plantings, as long as the existing trees are included in the Approved Plant List contained herein.

8. Owners are encouraged to vary the planting materials from lot to lot as much as possible to avoid a “cookie cutter” redundant streetscape appearance.
9. The ACC Reviewer, at its sole discretion, may approve a lesser number of plants and/or reduce the size of the planter beds due to constraints such as available space and lot size/configuration.

### City of Boerne Requirements

The City of Boerne must review landscape plans before issuing a Building Permit for the construction of homes ONLY on lots larger than 21,780 square feet. To receive a permit, lots greater than 21,780 square feet, must comply with the terms of City Ordinance 2007-64 (Boerne’s Zoning Ordinance), Article 4 “Tree Preservation Requirements”, as amended, using terms defined by Article 1, Section 6 of the Zoning District Use regulations set forth in City of Boerne Ordinance No. 2005-01 as of the Effective Date. Also see Section 3.51A of the CC&Rs.

As part of issuing a Certificate of Occupancy for lots greater than 21,780 square feet, the City will also inspect compliance of irrigation systems and the use of drought tolerant plant material approved by the ACC (reference the approved Plant List in this chapter). Also see the CC&Rs Section 3.51 H - M.

In addition, homeowners must comply with Chapter 22, Article I and Article II of the City of Boerne Code of Ordinances. Portions of the above-referenced ordinance address landscaping issues, including irrigation requirements.

Landscaping plans for lots less than 21,780 square feet in size will not need to be reviewed by the City.

LOT CLASSIFICATION TABLE (MINIMUMS)			
LOT TYPE	LOT CLASSIFICATION	LOT WIDTH	LOT SQ. FT.
GARDEN	GARDEN LOT	50	5,000
SF	TOWN LOT	50	5,500
SF	TRADITIONAL LOT	60	6,500
SF	MANOR LOT	70	8,000
SF	ESTATE LOT	80	11,250
SF	LARGE ESTATE LOT	90	12,500
SF	COUNTRY ESTATE LOT	100	20,300



## Garden, Town & Traditional Lot Landscape Requirements

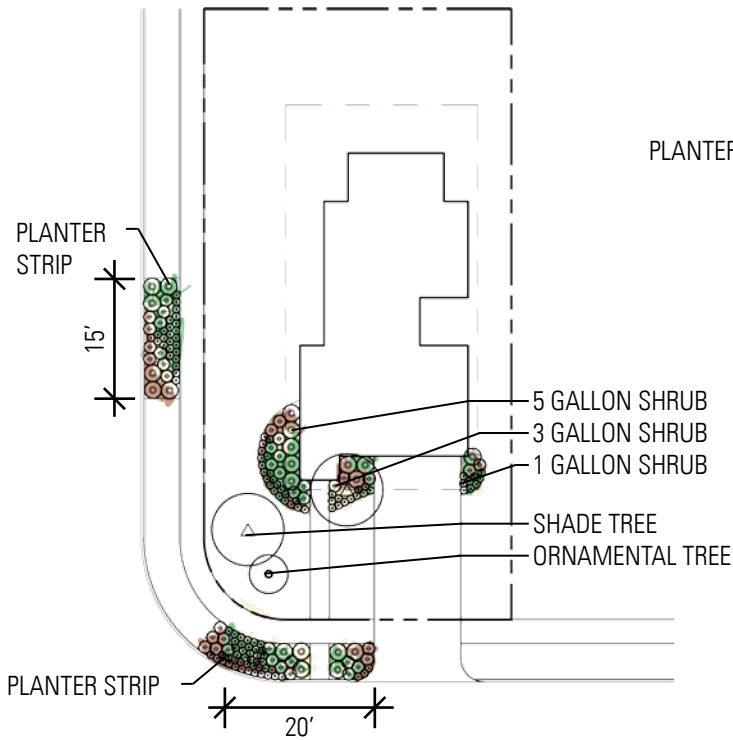

Corner Lot

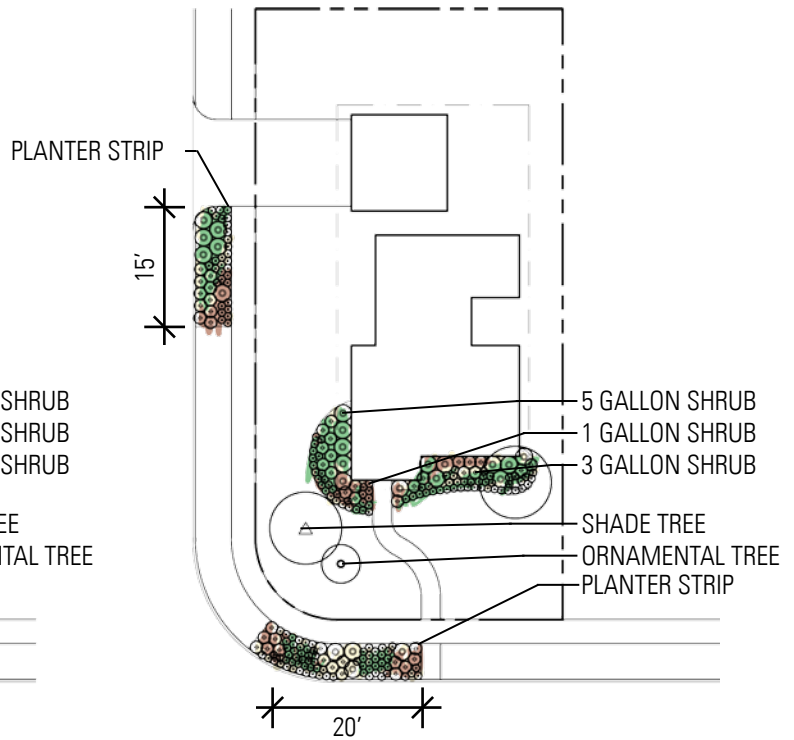

Corner Lot

	FRONT YARD MINIMUM PLANTING QUANTITIES				
	TREES		SHRUBS		
	SHADE TREE	ORNAMENTAL TREE	5 GALLON	3 GALLON	1 GALLON
GARDEN/TOWN/TRADITIONAL	1	1	7	10	20
MANOR	2	1	8	12	24
ESTATE/LARGE ESTATE	2	2	10	16	36
COUNTRY ESTATE	2	2	12	20	40

	PLANTER STRIP MINIMUM PLANTING QUANTITIES				
	TREES		SHRUBS		
	SHADE TREE	ORNAMENTAL TREE	5 GALLON	3 GALLON	1 GALLON
GARDEN/TOWN/TRADITIONAL	0	0	0	10	16
MANOR	0	0	0	10	16
ESTATE/LARGE ESTATE	0	0	0	12	18
COUNTRY ESTATE	0	0	0	16	20

\*Divide number of shrubs evenly between front planter strip and side planter strip

## Garden, Town & Traditional Lot Landscape Requirements

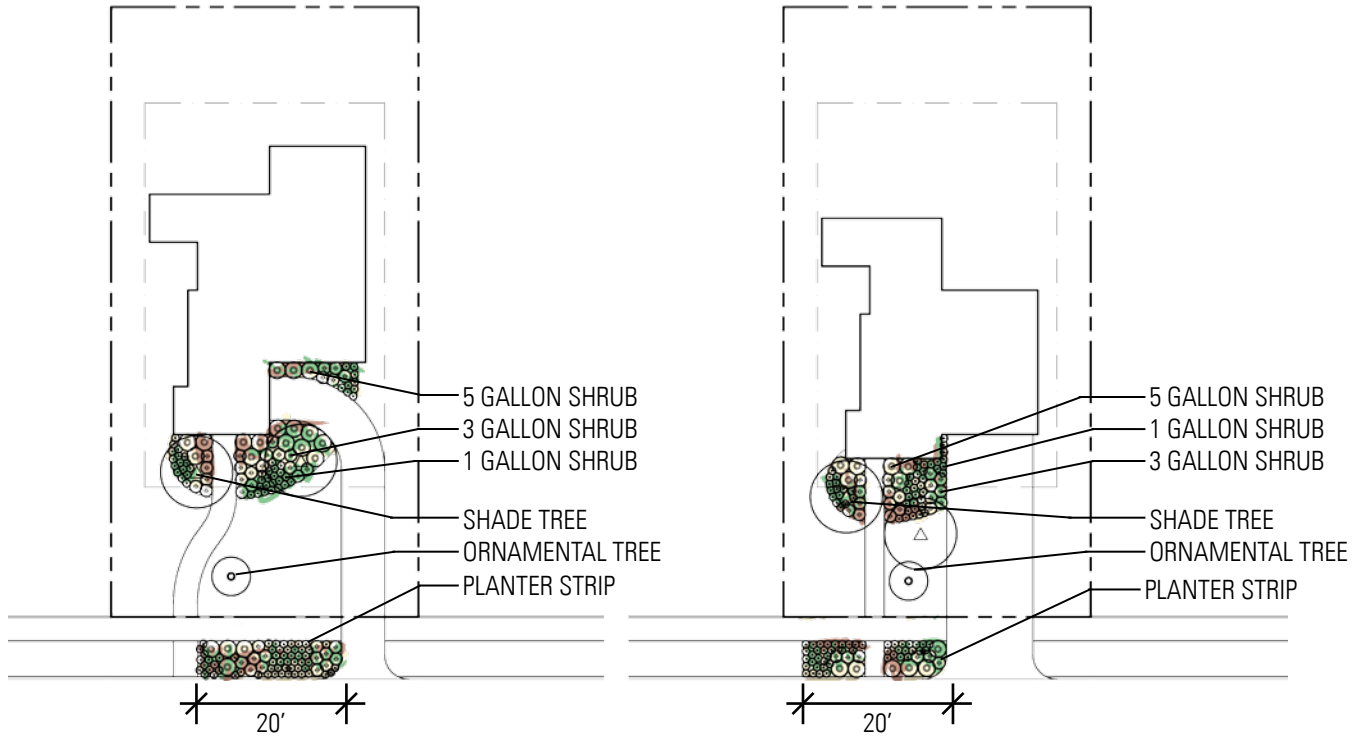

Interior Lot

Interior Lot

	FRONT YARD MINIMUM PLANTING QUANTITIES				
	TREES		SHRUBS		
	SHADE TREE	ORNAMENTAL TREE	5 GALLON	3 GALLON	1 GALLON
GARDEN/TOWN/TRADITIONAL	1	1	5	10	15
MANOR	2	1	5	10	15
ESTATE/LARGE ESTATE	2	2	10	16	30
COUNTRY ESTATE	2	2	12	20	36

	PLANTER STRIP MINIMUM PLANTING QUANTITIES				
	TREES		SHRUBS		
	SHADE TREE	ORNAMENTAL TREE	5 GALLON	3 GALLON	1 GALLON
GARDEN/TOWN/TRADITIONAL	0	0	0	6	10
MANOR	0	0	0	7	12
ESTATE/LARGE ESTATE	0	0	0	8	15
COUNTRY ESTATE	0	0	0	10	18

# Manor Lot Landscape Requirements

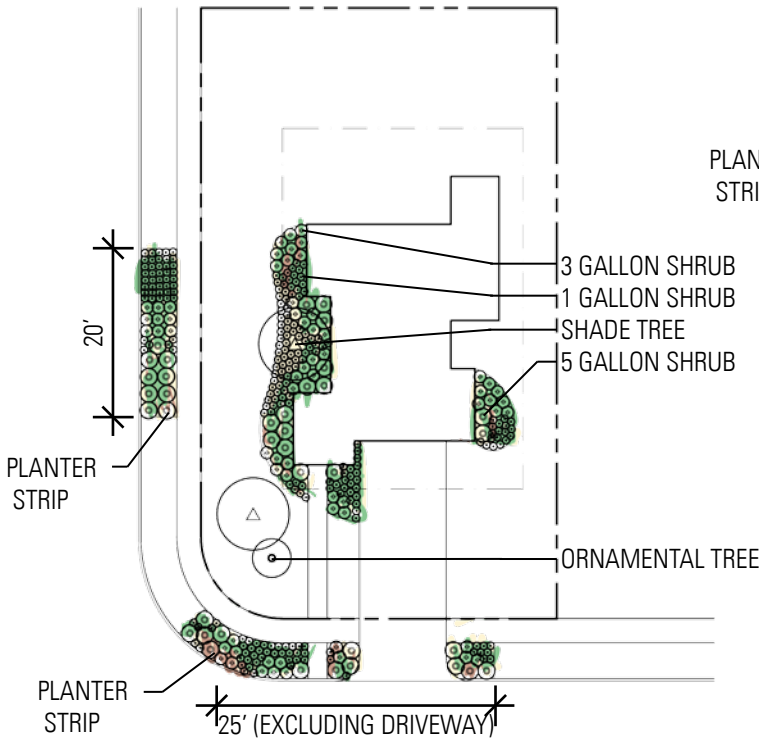

Corner Lot

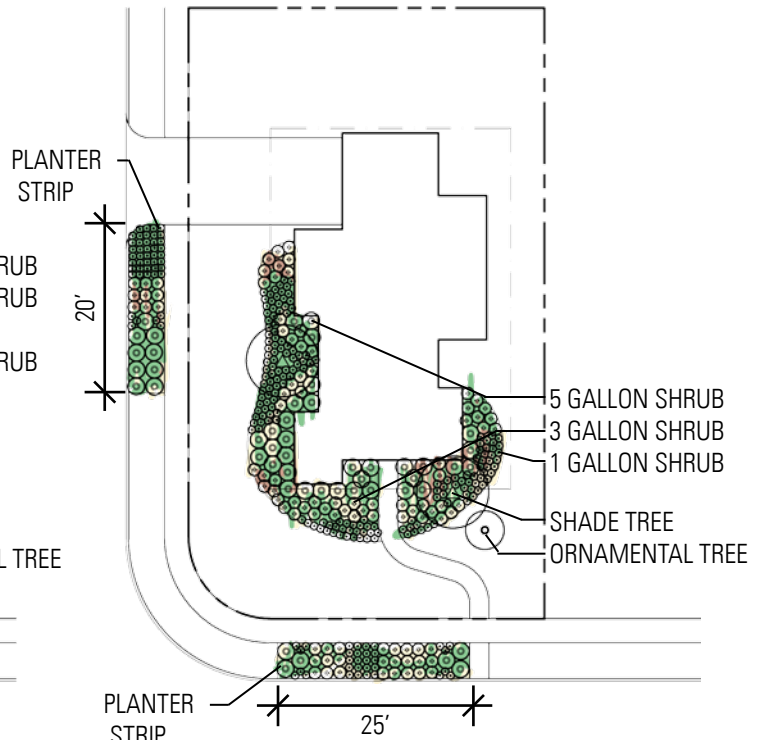

Corner Lot

	FRONT YARD MINIMUM PLANTING QUANTITIES				
	TREES		SHRUBS		
	SHADE TREE	ORNAMENTAL TREE	5 GALLON	3 GALLON	1 GALLON
GARDEN/TOWN/TRADITIONAL	1	1	7	10	20
<b>MANOR</b>	<b>2</b>	<b>1</b>	<b>8</b>	<b>12</b>	<b>24</b>
ESTATE/LARGE ESTATE	2	2	10	16	36
COUNTRY ESTATE	2	2	12	20	40

	PLANTER STRIP MINIMUM PLANTING QUANTITIES				
	TREES		SHRUBS		
	SHADE TREE	ORNAMENTAL TREE	5 GALLON	3 GALLON	1 GALLON
GARDEN/TOWN/TRADITIONAL	0	0	0	10	16
<b>MANOR</b>	<b>0</b>	<b>0</b>	<b>0</b>	<b>10</b>	<b>16</b>
ESTATE/LARGE ESTATE	0	0	0	12	18
COUNTRY ESTATE	0	0	0	16	20

\*Divide number of shrubs evenly between front planter strip and side planter strip

# Manor Lot Landscape Requirements

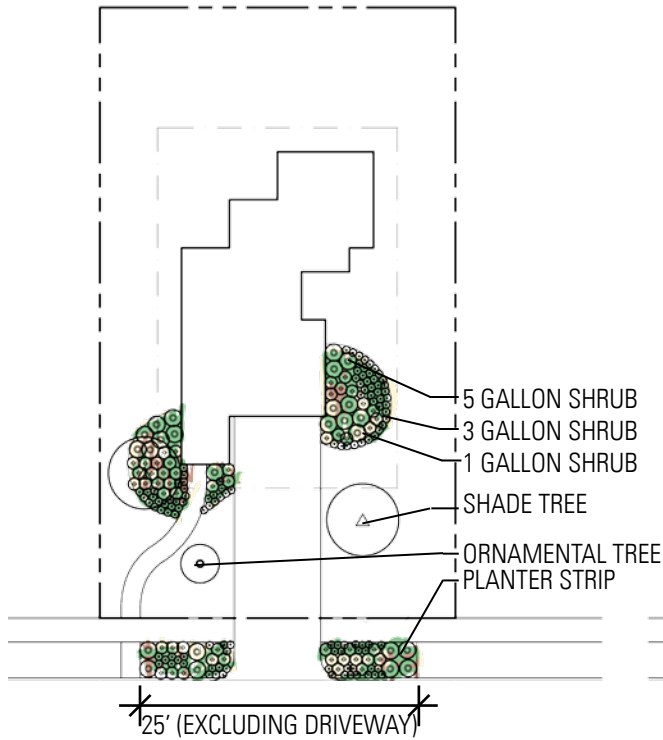

Interior Lot

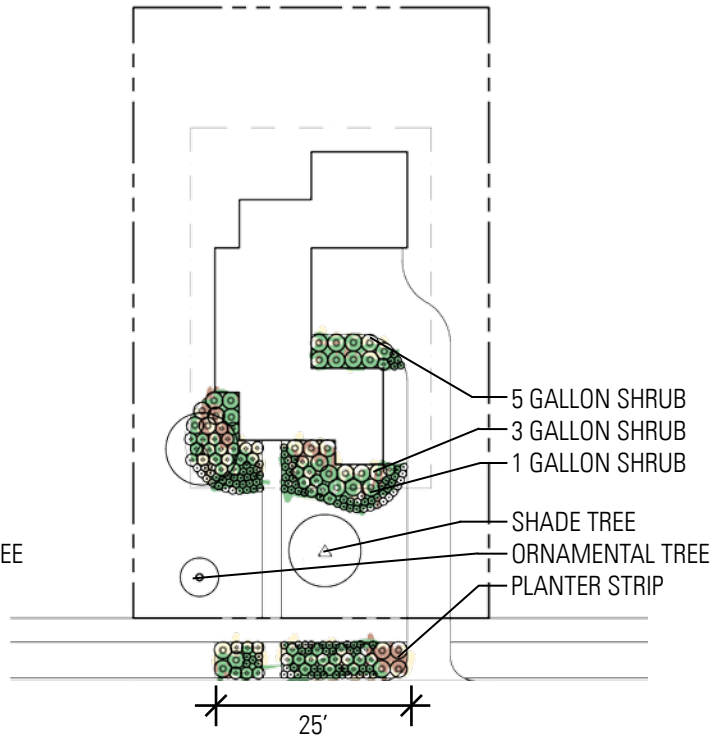

Interior Lot

	FRONT YARD MINIMUM PLANTING QUANTITIES				
	TREES		SHRUBS		
	SHADE TREE	ORNAMENTAL TREE	5 GALLON	3 GALLON	1 GALLON
GARDEN/TOWN/TRADITIONAL	1	1	5	10	15
<b>MANOR</b>	<b>2</b>	<b>1</b>	<b>5</b>	<b>10</b>	<b>15</b>
ESTATE/LARGE ESTATE	2	2	10	16	30
COUNTRY ESTATE	2	2	12	20	36

	PLANTER STRIP MINIMUM PLANTING QUANTITIES				
	TREES		SHRUBS		
	SHADE TREE	ORNAMENTAL TREE	5 GALLON	3 GALLON	1 GALLON
GARDEN/TOWN/TRADITIONAL	0	0	0	6	10
<b>MANOR</b>	<b>0</b>	<b>0</b>	<b>0</b>	<b>7</b>	<b>12</b>
ESTATE/LARGE ESTATE	0	0	0	8	15
COUNTRY ESTATE	0	0	0	10	18

## Estate and Large Estate Lot Landscape Requirements

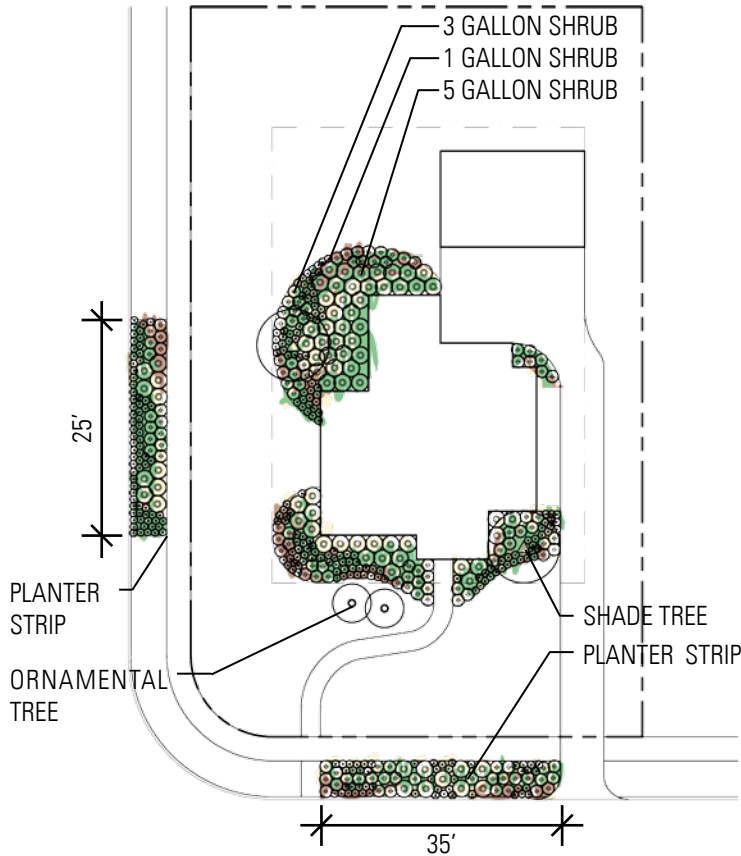

Corner Lot

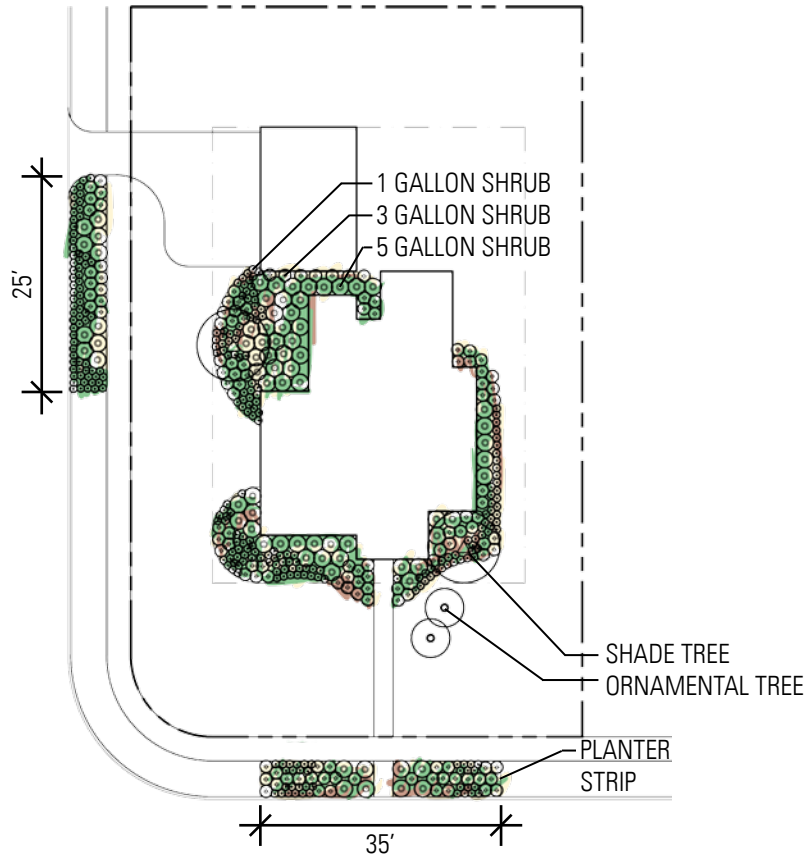

Corner Lot

	FRONT YARD MINIMUM PLANTING QUANTITIES				
	TREES		SHRUBS		
	SHADE TREE	ORNAMENTAL TREE	5 GALLON	3 GALLON	1 GALLON
GARDEN/TOWN/TRADITIONAL	1	1	7	10	20
MANOR	2	1	8	12	24
ESTATE/LARGE ESTATE	2	2	10	16	36
COUNTRY ESTATE	2	2	12	20	40

	PLANTER STRIP MINIMUM PLANTING QUANTITIES				
	TREES		SHRUBS		
	SHADE TREE	ORNAMENTAL TREE	5 GALLON	3 GALLON	1 GALLON
GARDEN/TOWN/TRADITIONAL	0	0	0	10	16
MANOR	0	0	0	10	16
ESTATE/LARGE ESTATE	0	0	0	12	18
COUNTRY ESTATE	0	0	0	16	20

\*Divide number of shrubs evenly between front planter strip and side planter strip

## Estate and Large Estate Lot Landscape Requirements

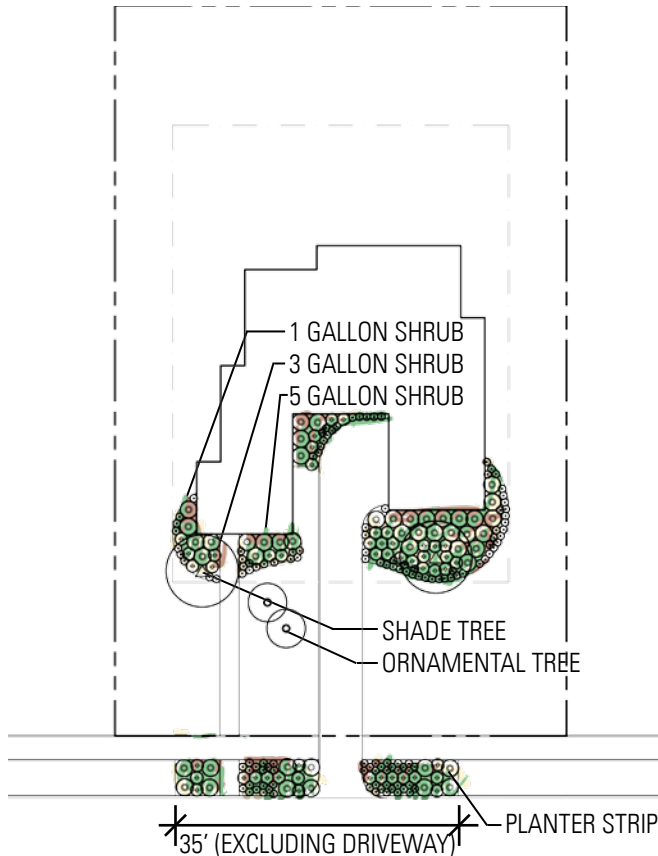

Interior Lot

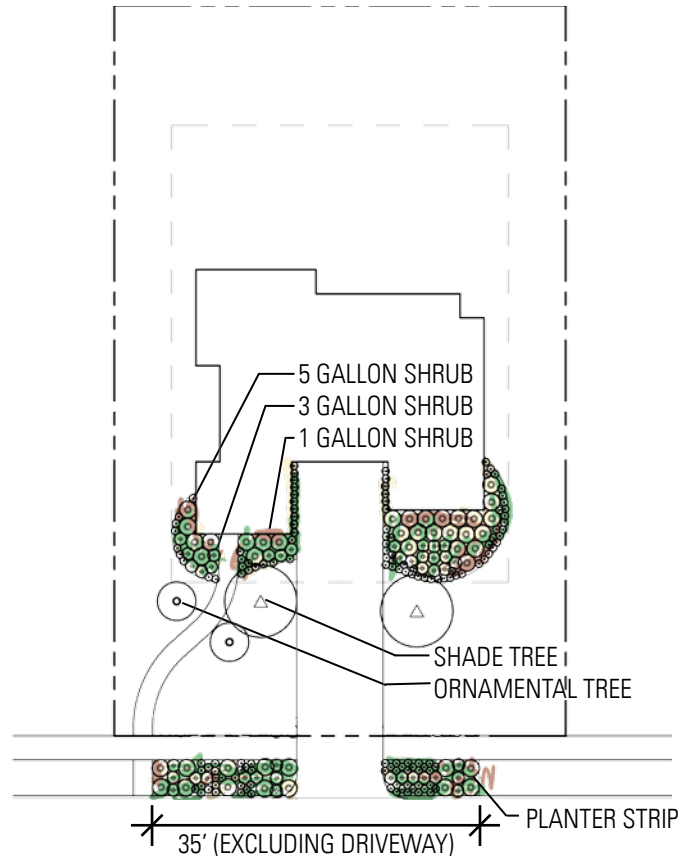

Interior Lot

	FRONT YARD MINIMUM PLANTING QUANTITIES				
	TREES		SHRUBS		
	SHADE TREE	ORNAMENTAL TREE	5 GALLON	3 GALLON	1 GALLON
GARDEN/TOWN/TRADITIONAL	1	1	5	10	15
MANOR	2	1	5	10	15
<b>ESTATE/LARGE ESTATE</b>	<b>2</b>	<b>2</b>	<b>10</b>	<b>16</b>	<b>30</b>
COUNTRY ESTATE	2	2	12	20	36

	PLANTER STRIP MINIMUM PLANTING QUANTITIES				
	TREES		SHRUBS		
	SHADE TREE	ORNAMENTAL TREE	5 GALLON	3 GALLON	1 GALLON
GARDEN/TOWN/TRADITIONAL	0	0	0	6	10
MANOR	0	0	0	7	12
<b>ESTATE/LARGE ESTATE</b>	<b>0</b>	<b>0</b>	<b>0</b>	<b>8</b>	<b>15</b>
COUNTRY ESTATE	0	0	0	10	18



## Country Estate Lot Landscape Requirements

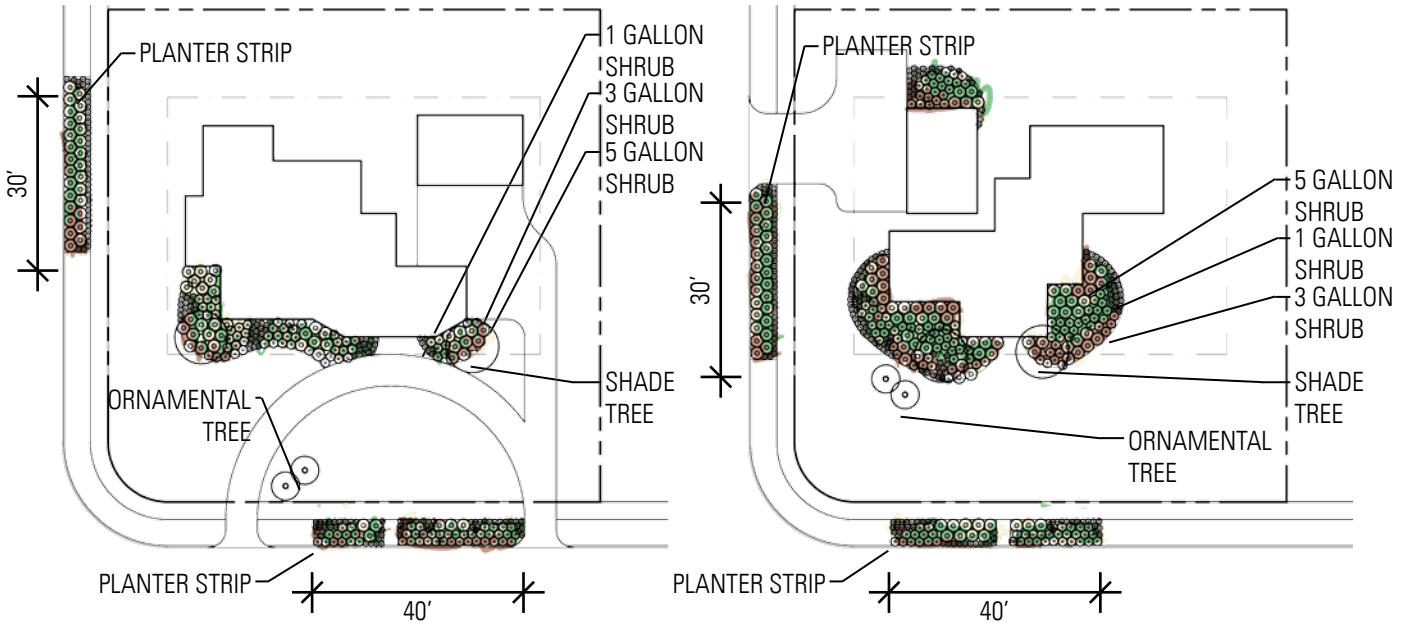

Corner Lot

Corner Lot

	FRONT YARD MINIMUM PLANTING QUANTITIES				
	TREES		SHRUBS		
	SHADE TREE	ORNAMENTAL TREE	5 GALLON	3 GALLON	1 GALLON
GARDEN/TOWN/TRADITIONAL	1	1	7	10	20
MANOR	2	1	8	12	24
ESTATE/LARGE ESTATE	2	2	10	16	36
<b>COUNTRY ESTATE</b>	<b>2</b>	<b>2</b>	<b>12</b>	<b>20</b>	<b>40</b>

	PLANTER STRIP MINIMUM PLANTING QUANTITIES				
	TREES		SHRUBS		
	SHADE TREE	ORNAMENTAL TREE	5 GALLON	3 GALLON	1 GALLON
GARDEN/TOWN/TRADITIONAL	0	0	0	10	16
MANOR	0	0	0	10	16
ESTATE/LARGE ESTATE	0	0	0	12	18
<b>COUNTRY ESTATE</b>	<b>0</b>	<b>0</b>	<b>0</b>	<b>16</b>	<b>20</b>

\*Divide number of shrubs evenly between front planter strip and side planter strip

# Country Estate Lot Landscape Requirements

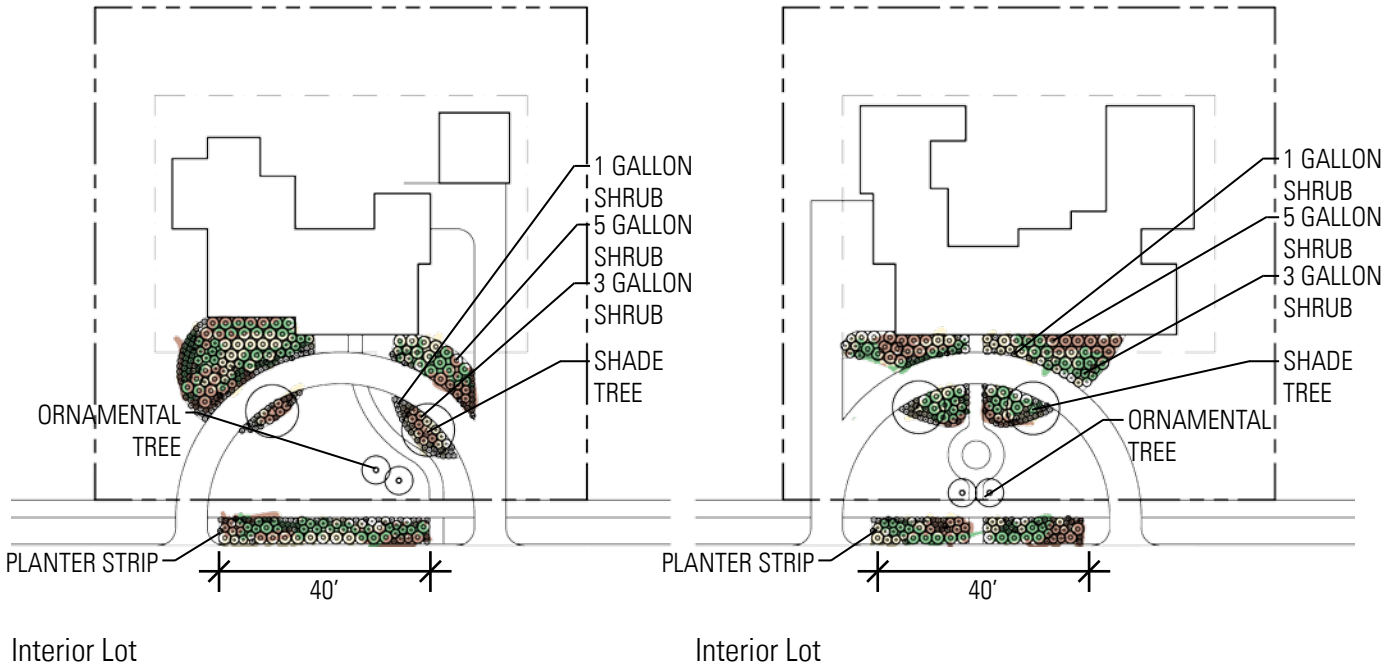

	FRONT YARD MINIMUM PLANTING QUANTITIES				
	TREES		SHRUBS		
	SHADE TREE	ORNAMENTAL TREE	5 GALLON	3 GALLON	1 GALLON
GARDEN/TOWN/TRADITIONAL MANOR	1	1	5	10	15
ESTATE/LARGE ESTATE	2	2	10	16	30
<b>COUNTRY ESTATE</b>	<b>2</b>	<b>2</b>	<b>12</b>	<b>20</b>	<b>36</b>

	PLANTER STRIP MINIMUM PLANTING QUANTITIES				
	TREES		SHRUBS		
	SHADE TREE	ORNAMENTAL TREE	5 GALLON	3 GALLON	1 GALLON
GARDEN/TOWN/TRADITIONAL MANOR	0	0	0	6	10
ESTATE/LARGE ESTATE	0	0	0	8	15
<b>COUNTRY ESTATE</b>	<b>0</b>	<b>0</b>	<b>0</b>	<b>10</b>	<b>18</b>

## Tree Preservation

Residential lots in Esperanza have been developed to preserve as many of the native trees as possible. Existing native trees provide the unity and constant “sense of green” help provide visual pleasure and enjoyment of the outdoor experience. The preservation of existing native trees is strongly encouraged.

In order to obtain a Building Permit, ONLY lots greater than 21,780 square feet must comply with the terms of Ordinance No. 2007-64 (Boerne’s Zoning Ordinance), Article 4 “Tree Preservation Requirements”, as amended, using terms defined by Article 1, Section 6 of the Zoning District Use regulations set forth in City of Boerne Ordinance No. 2005-01 as of the Effective Date.

Shade trees are trees which normally reach a height of more than 20 feet. Shade trees which are indigenous or adapted to this region of Texas include American Elm, Cedar Elm, Pecan, Cottonwood, Sycamore, and some varieties of Oak and Cypress.

Ornamental trees are trees which normally reach a height at maturity or are trimmed to maintain a maximum height of twenty (20) feet or less. Ornamental trees which are indigenous or adapted to this region of Texas include Crepe Myrtle, Redbud, Madrone, Possumhaw, Cherry, or Mountain Laurel.

## Plant Lists

The ACC Approved Plant List included in the following sections contain the desired plant materials for Esperanza. The use of these native plant materials have functional and aesthetic properties that are essential to the achievement of a sense of continuity and consistency in the Esperanza landscape concept. Every effort should be made to incorporate these plants into the landscape design for every lot. In particular, priority should be given to ecologically noninvasive plant materials. Other plant material may be used such as flowers, perennials and herbaceous plant materials, provided accepted regional landscape design practices are observed, but priority should be given to plants from this palette. Palm trees

are considered to be out of character with the desired landscape effect and are prohibited. Arborvitae, Italian cypress, junipers (other than ground cover varieties) and bamboo are prohibited.

See the Prohibited Plant List on the next page.



Image of Planting Concept



Image of Planting Concept

## **Prohibited Plant List**

St. Augustine turf  
Oleander (*Nerium Oleander*)  
Chinaberry (*Melia azedarach*)  
Nandina (*Nandinia Domestica*)  
Ligustrum (*Ligustrum japonicum*)  
Japanese Honeysuckle (*Lonicera japonica*)  
Tree of Heaven (*Alianthus altissima*)  
Lilac Chastetree- (*Vitex agnus-castus*)  
Palm Trees  
Arborvitae  
Italian Cypress  
Junipers (other than ground cover varieties)  
Texas Red Oak/Shumard Oak  
Bamboo

## **Revegetation**

All the disturbed areas must be revegetated at the earliest possible time following disturbance. Utility corridors, steep cuts, and access ways are to be revegetated following backfill and compaction.

## Approved Plant List

COMMON NAME	SCIENTIFIC NAME	TYPE	E/D	COMMENTS
<b>SHADE TREES</b>				
Bigtooth Maple	<i>Acer grandidentatum</i>	ST	D	fall color; best species for limestone soils; grows best when protected from west sun
Pecan	<i>Carya illinoensis</i>	ST	D	fall color
Bur Oak	<i>Quercus macrocarpa</i>	ST	D	very large acorns
Southern catalpa	<i>Catalpa bignonioides</i>	ST	D	large leaf showy flower
Escarpment Black Cherry	<i>Prunus serotina var. eximia</i>	ST	D	TX native white flowers
Mexican Sycamore	<i>Platanus mexicana</i>	ST	D	distinctive shaggy bark , fast growing
Thornless Texas Honey Mesquite	<i>Prosopis glandulosa Maverick®</i>	ST	D	lacy bright green foliage with smooth grey bark
Lacey Oak	<i>Quercus glaucoides</i>	ST	D	shade tree for small areas
Monterrey Oak	<i>Quercus polymorpha</i>	ST	SE	adapted, fast growing, resistant to oak wilt
Live Oak	<i>Quercus virginiana</i>	ST	E	ubiquitous in area
Lacebark Elm	<i>Ulmus parvifolia</i>	ST	D	unique bark
Texas Bald Cypress	<i>Taxodium distichum</i>	ST	D	copper foliage
Cedar Elm	<i>Ulmus crassifolia</i>	ST	D	gold foliage, fast growing
<b>ORNAMENTAL TREES</b>				
Anacacho Orchid Tree	<i>Bauhinia lunarioides</i>	OT	D	tx native, white flower spring
Texas Redbud	<i>Cercis canadensis var. texensis</i>	OT	D	Texas native, showy or fragrant flower, attractive seeds or fruit
Desert Willow	<i>Chilopsis linearis Art's Seedless®</i>	OT	SE	large, showy flowers produced during the heat of the summer provide months of color and attract hummingbirds
Mexican Olive	<i>Cordia boissieri</i>	OT	E	tx native spring, summer.grey green foliage,white flower
American Smoketree	<i>Cotinus obovatus</i>	OT	D	tx native, fall color, showy flower
Texas Persimmon	<i>Diospyros texana</i>	OT	D	tx native, fruit eaten by wildlife, slow growing
Loquat	<i>Eriobotrya japonica</i>	OT	E	fruit eaten by wildlife,can be messy
Yaupon (female)	<i>Ilex vomitoria</i>	OT	D	Tx native, seeds eaten by wildlife
Crape Myrtle	<i>Lagerstroemia indica</i>	OT	D	summer, color
Goldenball Leadtree	<i>Leucaena retusa</i>	OT	D	tx native, showy fragrant flower
Desert Museum Palo Verde	<i>Parkinsonia (Cercidium)x 'Desert Museum'</i>	OT	D	Thornless, fast-growing and upright
Texas Ebony	<i>Pithecellobium flexicaule</i>	OT	SE	tx native fragrant flower, seed eaten by wildlife
Mexican plum	<i>Prunus mexicana</i>	OT	D	white fragrant flowers
Flameleaf Sumac	<i>Rhus lanceolata</i>	OT	D	tx native, red fall color, large white flower spike
Evergreen sumac	<i>Rhus virens</i>	OT	E	hedge, fruit eaten by wildlife
Texas Mountain Laurel	<i>Sophora secundiflora</i>	OT	E	purple flowers
Eve's necklace	<i>Styphnolobium affine</i>	OT	E	tx native, showy pink/white wisteria-like bloom
Mexican Buckeye	<i>Ungnadia speciosa</i>	OT	D	tx native, pink flowers in Spring, seeds Winter interest
<b>GROUND COVER</b>				
Texas Gold Columbine	<i>Aquilegia chrysantha hinckleyana 'Texas Gold'</i>	GC	D	yellow bloom spring, native to Big Bend
Artemisia	<i>Artemisia 'Powis Castle'</i>	GC	E	blue gray
Fall Aster	<i>Aster oblongifolius</i>	GC	D	fall, purple
Texas Primrose	<i>Calylophus Berlandieri</i>	GC	D	Spring/summer yellow bloom
Damianita	<i>Chrysactinia mexicana</i>	GC	E	spring/some summer, yellow
Laceleaf coreopsis	<i>Coreopsis lanceolata</i>	GC	E	yellow flower tx native
Black Dalea	<i>Dalea frutescens</i>	GC	E	tx native, Purple bloom
Gregg's Silver Dalea	<i>Dalea greggii</i>	GC	E	tx native, pale green foliage
silver pony foot	<i>Dichondra argentea</i>	GC	E	silvergray foliage
Engelmann Daisy	<i>Engelmannia peristenia</i>	GC	e	showy flower
Indian Blanket	<i>Gaillardia pulchella</i>	GC	E	annual, reseeds
Pink Lantana	<i>Lantana camara</i>	GC	D	pink bloom
Purple Trailing Lantana	<i>Lantana Montevidensis</i>	GC	SE	spring to frost, lavender or white
Texas Lantana	<i>Lantana urticoides</i>	GC	D	yellow flowers turn orange
New Gold Lantana	<i>Lantana x 'New Gold'</i>	GC	D	yellow, spring to frost
Blackfoot Daisy	<i>Melampodium leucanthum</i>	GC	E	spring to summer, white
Pink Evening Primrose	<i>Oenothera speciosa</i>	GC	D	pink carpet bloom wildflower
Hill Country wild Foxglove	<i>Penstemon triflorus</i>	GC	D	tx native large purple flower spike
Mexican Hat	<i>Ratibida columnifera</i>	GC	D	tx native seeds eaten by bird
Trailing Rosemary	<i>Rosmarinus officinalis 'Postratum'</i>	GC	E	fragrant foliage
Black Eyed Susan	<i>Rudbeckia fulgida 'Goldsturm'</i>	GC	D	tx native seeds eaten by bird
Dwarf Mexican Petunia	<i>Ruellia brittoniana 'Katie'</i>	GC	E	Mex native, blue bloom
Gray Santolina	<i>Santolina chamaecyparissus</i>	GC	E	shrubby groundcover, fine textured aromatic, gray foliage
Green Santolina	<i>Santolina virens</i>	GC	E	yellow bloom spring
Pink Skullcap	<i>Scutellaria suffrutescens</i>	GC	E	low growing, tidy and mounding plant
Purple Heart	<i>Setcreasea pallida</i>	GC	E	Mex native, spreads easily
lamb's ear	<i>Stachys byzantina</i>	GC	D	gray fuzzy leaves
Dahlberg Daisy	<i>Thymophylla tenuiloba</i>	GC	E	tx native, yellow blom spring/fall
Spiderwort	<i>Tradescantia virginiana</i>	GC	D	tx native, deel blue bloom
Prairie Purple Verbena	<i>Verbena bipinnatifida</i>	GC	SE	tx native, deer resistant
Prairie Zinnia	<i>Zinnia grandiflora</i>	GC	D	mound shaped

## Approved Plant List

COMMON NAME	SCIENTIFIC NAME	TYPE	E/D	COMMENTS
<b>VINES</b>				
Coral Vine	<i>Antigonon leptopus</i>	V	D	pink/white/rose flowers
Cross vine	<i>Bignonia capreolata</i>	V	E	spring, yellow pink
Texas dawn Bougainvillea	<i>Bougainvillea 'Monas'</i>	V	E	pink, summer
Carolina Jessamine	<i>Gelsemium sempervirens</i>	V	SE	Hummingbirds, aromatic bloom
Coral honeysuckle	<i>Lonicera sempervirens</i>	V	E	Hummingbirds
Virginia Creeper	<i>Parthenocissus quinquefolia</i>	V	D	fall, scarlett foliage
Texas Wisteria	<i>Wisteria frutescens</i>	V	D	Spring, bluish lilac
<b>ORNAMENTAL GRASSES</b>				
Sideoats Grama	<i>Bouteloua curtipendula</i>	G	D	long-lived, tough, and tolerant of heat and drought
Blond Ambition Blue Grama	<i>Bouteloua gracilis 'Blond Ambition' PP#22049</i>	G	SE	chartreuse flowers that dance above the foliage
Gulf Muhly	<i>Muhlenbergia capillaris</i>	G	D	whispy, fall color
Bamboo Muhly	<i>Muhlenbergia dumosa</i>	G	D	fine texture
Bull Grass	<i>Muhlenbergia emersleyi El Toro®</i>	G	SE	showy rosy purple flowers
Lindheimer's Muhly	<i>Muhlenbergia lindheimeri</i>	G	E	large specimen grass
Deergrass	<i>Muhlenbergia rigens</i>	G	E	2 yrs to full size
Pink Flamingo	<i>Muhlenbergia X 'Pink Flamingo'</i>	G	D	use narrow spaces, deer & drought tolerant
Mexican Feather Grass	<i>Nassella tenuissima</i>	G	D	airy clumps
Bear Grass	<i>Nolina Microcarpa</i>	G	E	White bloom spike
Texas Bear Grass	<i>Nolina texana</i>	G	E	leaf tips fray to form white curly-Q's
Dwarf Fountain Grass	<i>Pennisetum alopecuroides 'Hameln'</i>	G	D	fountain-like flower displays; fall
Dwarf Purple Fountain Grass	<i>Pennisetum setaceum 'Eaton Canyon'</i>	G	D	purple foliage
Little bluestem	<i>Schizachyrium scoparium</i>	G	D	tx native winter interest
<b>SHRUBS</b>				
Butterfly Milkweed	<i>Asclepias tuberosa</i>	S	D	tx native, monarch food
Dwarf Abelia	<i>Abelia grandiflor 'dwarf variety'</i>	S	E	mid summer-mid fall
Flame acanthus	<i>Anisacanthus quadrifidus var. wrightii</i>	S	D	perennial humming bird
Prairie Artemisia	<i>Artemisia ludoviciana</i>	S	E	tx native
Tropical Milkweed	<i>Asclepias curassavica</i>	S	D	orange summer bloom
Pride of Barbados	<i>Caesalpinia pulcherrima</i>	S	D	summer to fall, red -orange
American Beautyberry	<i>Callicarpa americana</i>	S	D	winter interest, fruit eaten by wildlife
Dwarf Bottlebrush	<i>Callistemon citrinus 'Little John'</i>	S	E	attracts hummingbirds
African Iris	<i>Dietes bicolor</i>	S	E	bloom summer spring
Purple coneflower	<i>Echinacea purpurea</i>	S	D	daisy like flowers, attracts butterflies
Coralbean	<i>Erythrina herbacea</i>	S	D	thorns, large red flower spike, hummingbird
Gregg's Blue Mistflower	<i>Eupatorium greggi</i>	S	D	attracts butterflies
Golden Showers Thryallis	<i>Galphimia glauca</i>	S	E	Yellow flowers from spring to frost
Red Firebush	<i>Hamelia patens 'Red'</i>	S	D	hummingbird attracts
Maximilian Sunflower	<i>Helianthus maximiliani</i>	S	D	Tx native, seeds eaten by wildlife
Texas Star Hibiscus	<i>Hibiscus coccineus</i>	S	D	tx native, red bloom
Seagreen Juniper	<i>Juniperus x pfitzeriana 'Sea Green'</i>	S	E	hardy, foundation shrub
Texas Sage	<i>Leucophyllum frutescens</i>	S	E	purple, pink, white-year round
Chihuahuan Sage	<i>Leucophyllum laevigatum</i>	S	E	spiky form and small olive-green leaves
Lynn's Legacy	<i>Leucophyllum langmaniae 'Lynn's Legacy'</i>	S	E	blooms more often than other selections
Agarita	<i>Mahonia trifoliolata</i>	S	E	yellow flower, red berries
Jerusalem Sage	<i>Phlomis fruticosa</i>	S	E	yellow, spring and summer
Garden Phlox	<i>Phlox paniculata 'John Fanick'</i>	S	D	pink bloom summer compact habit
Plumbago	<i>Plumbago auriculata</i>	S	D	sky blue
Mexican Oregano	<i>Poliomintha longifolia</i>	S	E	lavender, summer
Nearly Wild Rose	<i>Rosa 'Nearly Wild'</i>	S	SE	brigh pink, white center
Knockout Rose	<i>Rosa 'Radtko'</i>	S	E	spring to frost, bright pink
Belinda's dream rose	<i>Rosa x 'Belinda's Dream'</i>	S	E	large pink blooms
Upright Rosemary	<i>Rosmarinus officinalis</i>	S	E	upright shrub
Firecracker Fern	<i>Russelia equisetiformis</i>	S	E	Spring blooms, Year around evergreen foliage.
Scarlet Sage	<i>Salvia coccinea</i>	S	D	easily reseed
Mealy Blue Sage	<i>Salvia farinacea</i>	S	D	tx native, pale blue bloom
Henry duelberg' Salvia	<i>Salvia farinacea 'Henry Duelberg'</i>	S	D	purple bloom
Autumn Sage	<i>Salvia greggii</i>	S	E	1" long blooms, attracts hummingbirds
Mexican Bush Sage	<i>Salvia leucantha</i>	S	D	Large purple flower spikes
Cedar Sage	<i>Salvia roemeriana</i>	S	D	red flowers, does well in shade
Giant Goldenrod	<i>Solidago gigantea</i>	S	D	tall flower spike
Mexican bush marigold	<i>Tagetes lemmonii 'Compacta'</i>	S	D	yellow bloom
Esperanza	<i>Tecoma Stans</i>	S	D	yellow, spring -fall
Sierra Apricot Esperanza	<i>Tecoma Stans 'Orange Jubilee'</i>	S	D	apricot
<b>SUCCULENTS/ CACTI</b>				
Agave/ Century Plant	<i>Agave americana</i>	S/C	E	heat tolerant
Agave Cornelius	<i>Agave americana v 'Cornelius'</i>	S/C	E	yellow green leaf
Agave Marginata	<i>Agave americana v. 'Marginata'</i>	S/C	E	yellow stripe variegated
White-Striped Century Plant	<i>Agave americana v. 'Mediopicia Alba'</i>	S/C	E	white stripe variegated



## Approved Plant List

COMMON NAME	SCIENTIFIC NAME	TYPE	E/D	COMMENTS
Squid Agave	<i>Agave bracteosa</i>	S/C	E	creamy white
Octopus Agave	<i>Agave vilmoriana</i>	S/C	E	very unusual looking, octopus w/ outreaching tentacles
Agave Celsii	<i>Agave Celsii</i>	S/C	E	olive green large bloom spike
Harvard Agave	<i>Agave Havardiana</i>	S/C	E	blue foliage
Artichoke Agave	<i>Agave parryi v. truncata</i>	S/C	E	dense symmetrical form, ornamental
Queen Victoria Agave	<i>Agave victoriae reginae</i>	S/C	E	attractive small clump forming agave
Weber Agave	<i>Agave weberi</i>	S/C	E	wide, fleshy gray-green leaves
Blue Elf Aloe	<i>Aloe 'Blue Elf'</i>	S/C	E	attracts hummingbirds
Yellow bulbine	<i>Bulbine frutescens</i>	S/C	E	year round bloom yellow
Orange bulbine	<i>Bulbine frutescens 'Tiny Tangerine'</i>	S/C	E	year round bloom orange
Texas Sotol	<i>Dasyliirion texanum</i>	S/C	E	sculptural, spectacular flower stalks,
Grey Desert Spoon	<i>Dasyliirion wheeleri</i>	S/C	E	low maintenance, desert garden
Golden Barrel Cactus	<i>Echinocactus grusonii</i>	S/C	E	globe shaped cactus
Gopher Plant	<i>Euphorbia rigida</i>	S/C	E	Broad clusters of chartreuse flowers
Ghost Plant	<i>Graptopetalum paraguayense</i>	S/C	E	Forms trailing rosettes
Giant hesperaloe	<i>Hesperaloe funifera</i>	S/C	E	stemless, upright plant has stiff, broad
Crimson Yucca	<i>Hesperaloe parviflora 'Perpa' Brakelights®</i>	S/C	E	vivid red flowers compact growth habit
Yellow Hesperaloe	<i>Hesperaloe parviflora 'Yellow'</i>	S/C	E	carefree plant, long-lasting flower spikes
Pink Parade®	<i>Hesperaloe X Pink Parade® PP# 21828</i>	S/C	E	8-foot-tall flower spikes remain very straight
Macho Manfreda	<i>Manfreda 'Macho Mocha'</i>	S/C	E	purple foliage winter
Texas Manfreda	<i>Manfreda maculosa</i>	S/C	E	tx native, pale green spotted foliage
Spotted Manfreda	<i>Manfreda 'Spot'</i>	S/C	E	Varigated foliage
Blue Myrtle cactus	<i>Myrtillocactus geometrizans</i>	S/C	E	mex native, large column cactus
Engelmann's Prickly Pear	<i>Opuntia engelmannii</i>	S/C	E	texas native, fragrant flower, attractive seeds or fruit
Spineless Prickly Pear	<i>Opuntia cacanapa 'Ellisiana'</i>	S/C	E	yellow flower
Old Mexico Prickly Pear	<i>Opuntia gomei 'Old Mexico'</i>	S/C	E	yellow, undulating pad edges, spineless
Purple Prickly Pear	<i>Opuntia Santa Rita 'Tubac'</i>	S/C	E	yellow flower, accent
Banana Yucca	<i>Yucca baccata</i>	S/C	E	tough durable, extreme heat and cold
Spanish Dagger	<i>Yucca faxoniana</i>	S/C	E	tree-like
Adam's Needle	<i>Yucca filamentosa</i>	S/C	E	attracts butterflies
Tree Yucca	<i>Yucca filifera</i>	S/C	E	large flower spike
Pale Leaf Yucca	<i>Yucca pallida</i>	S/C	E	excellent low maintenance groundcover
Narrow leaf Yucca	<i>Yucca reverchonii</i>	S/C	E	yellow flower spike
Blue Yucca	<i>Yucca rigida</i>	S/C	E	Blue foliage
Beaked Yucca	<i>Yucca rostrata</i>	S/C	E	spectacular summer creamy white flowers
Twisted Leaf Yucca	<i>Yucca rupicola</i>	S/C	E	petite, stemless yucca, bright green leaves
Thompson Yucca	<i>Yucca thompsoniana</i>	S/C	E	small trunk-forming species,
SHADE PLANTS				
Shrimp plant	<i>Justicia brandegeana</i>	S	D	Interesting flower shape
Winterbourn Philodendron	<i>Philodendron Xanadu</i>	S	E	tropical form
Variegated Ginger	<i>Alpinia zerumbet 'Variegata'</i>	S	E	fast growing
Foxtail Fern	<i>Asparagus densiflorus 'Myers'</i>	S	E	border, container, mass
Cast Iron Plant	<i>Aspidistra elatior</i>	S	E	can handle deep shade
Turk's Cap	<i>Malva viscus arboreus var. Drummondii</i>	S	D	Tx native, red blooms summer
Ruellia	<i>Ruellia x brittoniana</i>	S	E	attracts butterfly
River Fern	<i>Thelypteris kunthii</i>	S	SE	fast grower
SCREENING PLANTS *				
Wax Myrtle	<i>Morella Cerifera</i>	S	E	excellent hedge or screening plant
Cleyera	<i>Ternstroemia gymnanthera</i>	S	E	excellent hedge of screening plant
Red tip Photinia	<i>Photinia x fraseri</i>	S	E	excellent hedge of screening plant
Sandankwa Viburnum	<i>Viburnum Suspensum</i>	S	E	excellent hedge of screening plant

\*All screening plants listed here must be pruned regularly and kept free from fungus. The red tip photinia is prohibited on corner lots in the side yard facing the street; otherwise the red tip photinia is allowed on residential lots

## Irrigation

All new homes are required to have automatic yard irrigation systems sufficient to provide proper amounts of water to landscaping within the entire yard. Sprinkler heads shall be located to effectively water the intended area with minimum overthrow or runoff onto pavement, driveways, streets, sidewalks, walks, etc. Irrigation should not spray into the street. Heads should be placed to insure full and effective coverage. Systems should have a rain sensor over-ride switch. Irrigation controllers should be located inside the garage. The homeowner should be instructed in the operation of the system so as to not over or under water the landscaping or allow excessive run off. Additionally, all irrigations shall comply with the following:

- The system must include automated rain sensors and programmable irrigation controllers. Unless otherwise approved by the ACC, the list of approved irrigation controllers is as follows: Weather\*Matic Smartline Series, Hunter "ETSystem," Rainbird "ET Manager", Weather Trak, and the Toro Intelli-Sense Series;
- All water for irrigation will be supplied by a reclaim system dedicated for irrigation only. Each residential unit will be required to install and pay all fees for a water meter dedicated for irrigation only. No automatic irrigation system may be connected to the potable water system;
- All residential and commercial owners, except for the BIRD school sites, must use drought tolerant plant materials approved by the ACC (Reference ACC Approved Plant List);
- Trenching for lines is not to encroach within the drip lines of existing trees;
- Lots in excess of twelve thousand five hundred (12,500) square feet should only irrigate the area that lies within seventy five (75) feet of the main residence.
- Must comply with Chapter 22, Article II, Divisions 1 and 2, of the City of Boerne Code of Ordinances (includes the City of Boerne's Drought Management Plan);
- Automatic irrigation systems are required;
- All planting beds should use drip irrigation;
- The drilling of private water wells for any purpose, including irrigation purposes, is strictly prohibited;
- Also see the CCRs Section 3.51.

## Drainage & Grading

Existing drainage patterns are to be maintained both during and after construction. Any new drainage ways are to appear and function like natural drainage ways and utilize material native to the site. If portions of drainage structures are visible, they must be faced with ACC approved stone. Additionally, any drainage resulting from development is to be dispersed on-site and not directed onto other lots. Gutters and down spouts may be required at the discretion of the ACC to improve the drainage quality; however concentrated drainage shall not be directed onto adjacent property. It is the responsibility of each builder to install adequate erosion control measures prior to the start of construction and to maintain controls throughout the entire construction process until project completion. Positive drainage away from the building shall be provided for rainfall, gutter downspouts, irrigation, air conditioner condensate and all other types of water runoff. Caution should be used in establishing the foundation elevation so that retaining walls, slabs or insufficient fall does not impair adequate drainage of the lot. It is the responsibility of the Builder to provide positive drainage for each lot.

Berms are to be graded in gentle, undulating naturalistic forms, and not straight or steep slopes. Provisions are to be made for drainage around or through berms as required. Generally, a height of forty-eight inches (48") from top of adjacent curb is the maximum preferred. Swales (small ditches) are to be graded shallow, but wide to slow runoff. Avoid steep cuts for natural look. Steep slopes of 2.5: 1 or more should be broken with retaining walls or steps. All retaining walls shall be submitted to and approved by the ACC prior to construction. Retaining walls should be designed to use materials such as stone, brick, or interlocking wall systems, refer to the Architectural Elements and External Decorations Chapter. Railroad ties, and landscape timbers are discouraged.

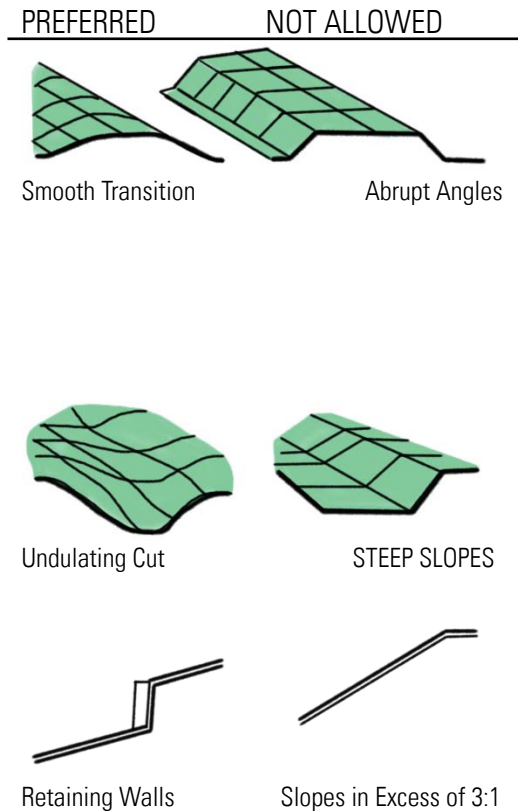

# STREETSCAPE IMPROVEMENTS



## General

The following paragraphs describe various design features that are recommended to establish a visual uniformity and landscape hierarchy throughout the development.

Through a comprehensive program of right-of-way landscaping, a sense of continuity can be fostered within the community. Landscape details can reinforce the desired community image in the various areas of the neighborhoods. Key intersections will be accented, view corridors should be enhanced, and selected areas should be screened to decrease their visual impact.

Landscaping can reduce the negative impact of traffic noise and can improve the visual quality of the community. The perceived image of the community can be greatly enhanced through berms, screening, and other improvements along the right-of-way.

## Sidewalks

Sidewalks with a five-foot (5') minimum width are to be constructed by the Builder within all public street right of way frontages. All walks are to be constructed in a consistent manner producing a uniform appearance

Locations of sidewalks are not to be varied except where required to avoid specimen trees or fire hydrants, light poles or other infrastructure. Gentle radii instead of abrupt curves and angles are required for transitions.

Expansion joints shall occur every twenty feet (20'). Construction joints scored 1/3rd of the concrete thickness shall occur every five feet (5'). Complete pours between expansion joints are required. No cold joints are permitted.

Drill dowels into concrete driveways and use expansion joints at connections of existing and new concrete. Dowels are to be stubbed out eighteen-inches (18") where sidewalk is to be continued in the future.

Where sidewalks cross driveways with decorative paving, the standard sidewalk design does not have to be carried through the driveway. Manholes and valve boxes located within sidewalks shall be flush with the concrete paving.

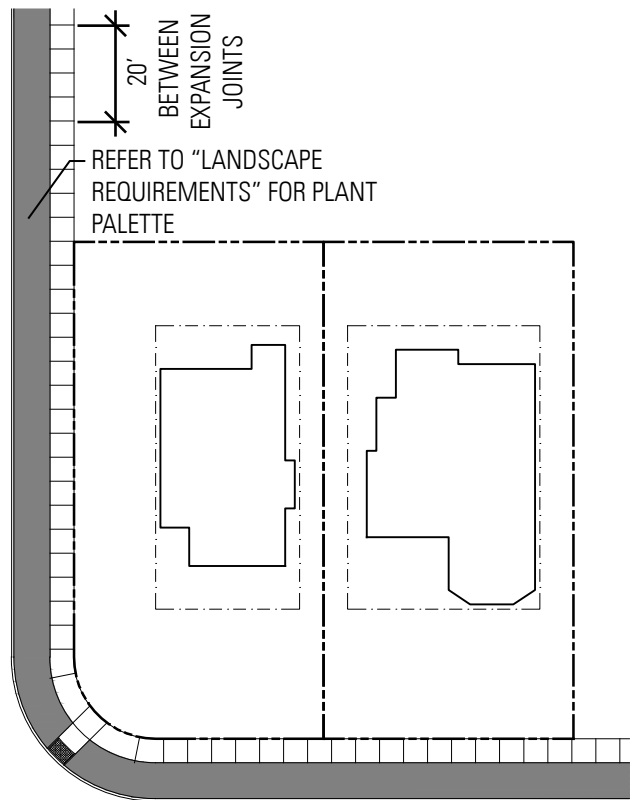

Sidewalk Exhibit

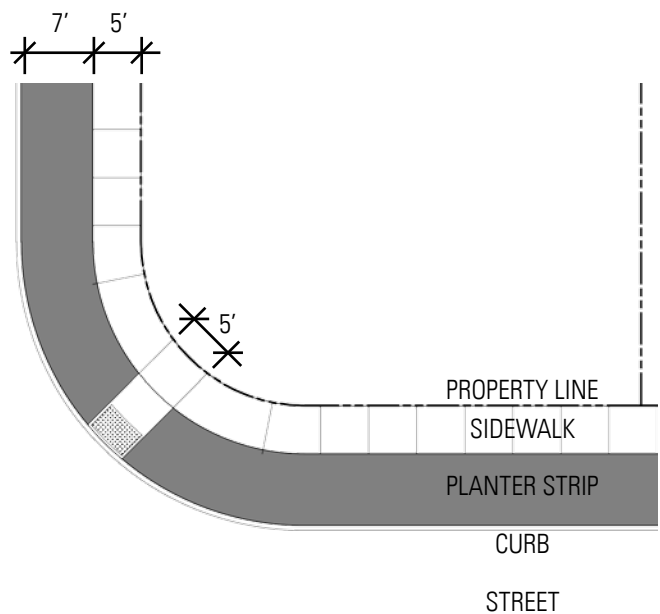

Sidewalk Dimensions

Manhole and valve box adjustments may be required, and are the responsibility of the Builder to coordinate with and pay the municipality, county or municipal utility district for any adjustments.

All sidewalk construction is to meet or exceed county and municipal standards.

Street sidewalks shall be installed by the builder on their Lots. The developer will install the required sidewalk ADA ramps. For reference, sidewalks are specified on the Plat.

Also see the CC&Rs Section 3.30.

### **Planter Strips**

All Planter Strips must be landscaped using the landscaping palettes selected from the Plant List - refer to the Landscape Requirement Chapter. No trees or mulch are allowed in the Planter Strips. Only low growing shrubs (shrubs that will not exceed thirty six inches (36") in height at maturity) and river rock are allowed in the Planter Strips. However, turf grass may be used as ground cover in the side yard planter strip on corner lots only. If turf grass is used as ground cover in the side yard planter strip on a corner lot, a minimum of 3" river rock must be used as ground cover in the planting bed.



# FENCES AND WALLS

## General

The vision of Esperanza is to balance the homeowner's desire for fencing and containment while retaining a strong community-wide connection to open space. The importance of privacy is recognized as a priority for homeowners; however, fencing placement, material and design should be sensitive towards its impact on adjacent lots, maintenance cost, the character of the streetscape and open space views.

## Prohibited Fences

Typical solid wood fence is fraught with many problems as indicated in the following list:

- hinders viewscapes;
- ages with exposure causing warp and rot;
- never uniform in appearance and often stained a myriad of colors;
- high maintenance and costly to replace at 6-10 years;
- helps disburse a wildfire;
- introduces insects and termites to a community of masonry homes;
- may lean or fall, creating a hazard;
- causes an ongoing enforcement issue with the HOA;
- creates a grid-like appearance to the community, while nature is more curvilinear;
- creates no room for creativity on the part of homeowners, no sense of a common aesthetic; and
- wood is a hardscape, not an organic "softscape".

Therefore, no wooden fences are allowed in Esperanza. Diagonal and horizontal fencing is not allowed. Chain link fence is not allowed.

## Approved Fences

Only native stone veneer or steel picket fences, preferably enhanced by trees, shrubs and plant screening, are allowed in Esperanza, as described below:

- Individual lots are not required to be fully enclosed with a perimeter fence. If fencing is used, it shall comply in all respects, including size and location,

with applicable governmental, City, County and State requirements. Fencing material, height and design must comply with these guidelines and the CC&R's.

- Fence Maintenance: Except for Association maintained fencing (fencing that is installed by the master developer or builder to separate adjacent lots from an open space area, landscape easement or roadway), the "common side and rear yard fence" shall be maintained by the owner on whose lot the common fence is built. Side and rear yard fences and walls shall be built upon one property (as close as possible to the property line), and not straddle any property line - also see page 36 - **Fencing Locations**. The costs associated with the maintenance of such fence or wall shall be the obligation of the owner of the lot on whose lot such fence or wall is built. However, the owner(s) of adjacent lots who tie-in to a fence or wall are highly encouraged to be good neighbors and pay one-half of the costs to maintain such common fence or wall. Such cost sharing arrangements are solely between homeowners and the Association has no duty or obligation to resolve cost sharing disputes between homeowners.
- Disputes concerning the cost, timing or other applicable issues related to the repair or replacement of Association maintained fencing and walls, or a portion thereof, should be directed to the Association.
- Native stone or steel picket fences built to the ACC design standards as shown and described on pages 34-47 herein, are the only acceptable fences allowed in all areas of the project subject to ACC approval.
- Steel picket fencing, which is enhanced by trees, shrubs and plant screening (living fences), is strongly encouraged.
- All mortar joints on stone veneer fences must be white; gray mortar joints are strictly prohibited.
- Also see the CC&Rs, Sections 3.32, 3.51 and 3.54

## Fencing Locations

Fencing placement is subject to various restrictions relative to location. The following basic rules must be adhered to:

- Fencing (in its entirety) is solely restricted to the owner's property.
- Rear and side yard fences and walls must be installed along the rear and side property line as close as possible to the property line, except that street side fencing on the corner lots must be **constructed parallel to the side yard sidewalk and must be setback a minimum of five feet (5') and a maximum of ten feet (10') from the sidewalk.**
- The owner(s) of adjacent lots must be allowed to tie-in to the fence or wall built along the adjacent common property line.
- The costs associated with the construction of such fence or wall is the obligation of the owner of the lot on which such fence is built. However, the owner(s) of adjacent lots who tie-in to a fence or wall are highly encouraged to be good neighbors and pay or reimburse the fence owner for one-half of the cost to construct such common fence or wall. Such cost sharing arrangements are solely between homeowners and the Association has no duty or obligation to resolve cost sharing disputes between homeowners.
- Fencing shall not be placed between the front yard building line and property line. Fences must comply with the City of Boerne Subdivision Ordinances on a side yard building setback on corner lots with secondary street frontage.
- Fencing must be set back a minimum distance of ten feet (10'-0") from the front facade or building line of the dwelling, but cannot be located behind the rear side corners of the dwelling.
- Front fencing must be constructed perpendicular and commencing from the side of the dwelling to the adjacent side boundary line of the lot (or street side fencing if on a corner lot).
- Double fencing is prohibited.
- No wooden fencing is allowed.
- Fencing installed along property lines where retaining walls exist shall be located on the high side of the wall. Vertical fence poles/posts may not be placed within the retaining wall structure.
- Also see the CC&Rs, Sections 3.32, 3.51 and 3.54.

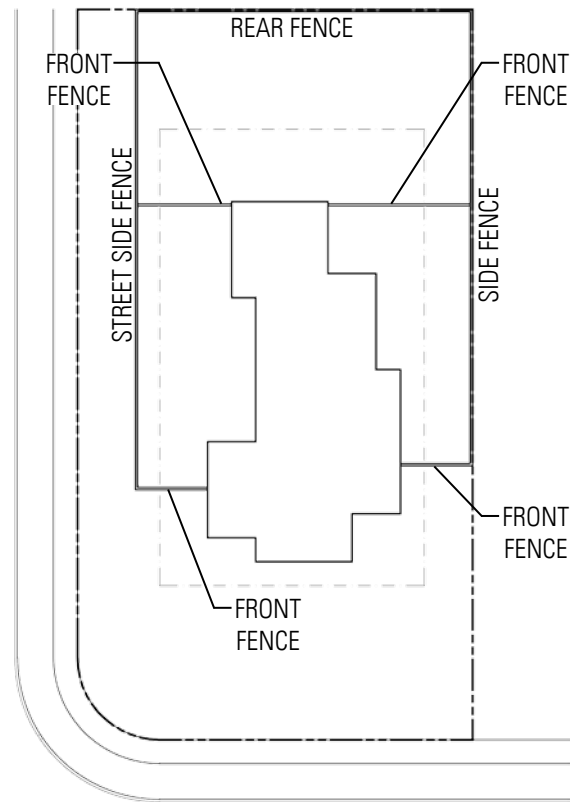

Corner Lot Nomenclature

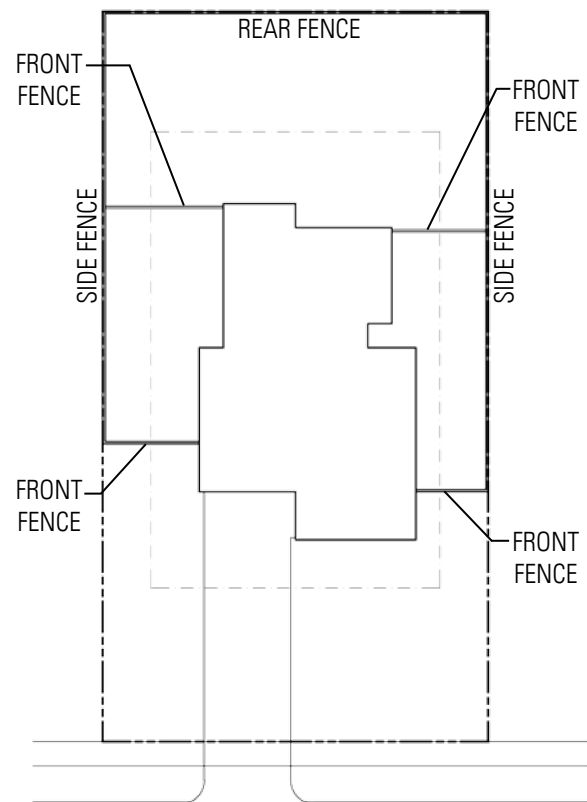

Interior Lot Nomenclature

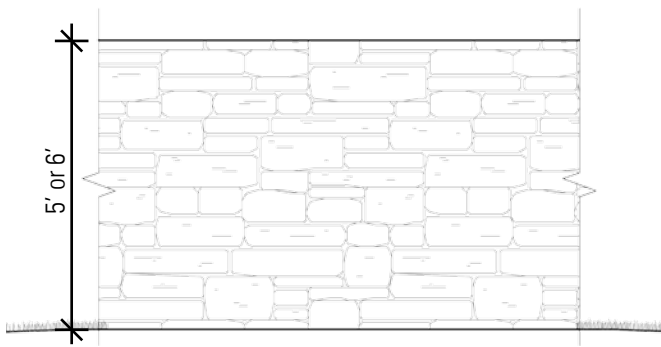

Type 'A' Fence

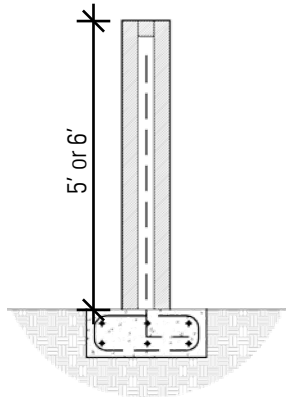

Type 'A' Fence Cross Section

## Setbacks

A minimum front fence setback of ten feet (10') from the front face of the house is required. The street side fence and/or screening plant setback must be a minimum of five feet (5') and a maximum of ten feet (10') from the side street sidewalk on a corner lot. If both a fence and screening plants are installed along the side street of a corner lot, the screening plants must be planted inside the fence.

## Fence Types & Heights

A Type 'A' fence consists of a native stone veneer fence, while Type 'B' Fence is constructed of metal. All fences located along or adjacent to a boulevard must be 6' in height. All fences used to enclose the back yard of a residential lot must be 5' tall unless a side fence is located along or adjacent to a boulevard, in which case that side fence must be 6' in height. Type 'B' metal fences shall be installed at a consistent height where possible. Top rail shall be level. Bottom rail of metal fence should be two inches (2") above finish grade. Where finished grade changes, the metal fence should be stepped at equal intervals such that the bottom rail is no less than two inches (2") and no more than six inches (6") above finish grade. Two inch (2") metal posts shall be installed between a minimum three foot (3') and maximum eight-foot (8') spacing. A Type 'B' Living Fence consists of steel picket fencing constructed to be 5' or 6' in height, enhanced by trees, shrubs, and plant screening. If full screening is required, full screening must be achieved within 24 months of the builder closing on the sale of the home to the home buyer. (Reference the Type 'B' Living Fence option section in this chapter)

All fences must be constructed to the specifications provided herein and in the CC&Rs. (Reference the CC&R's, Sections 3.32, 3.51 and 3.54).

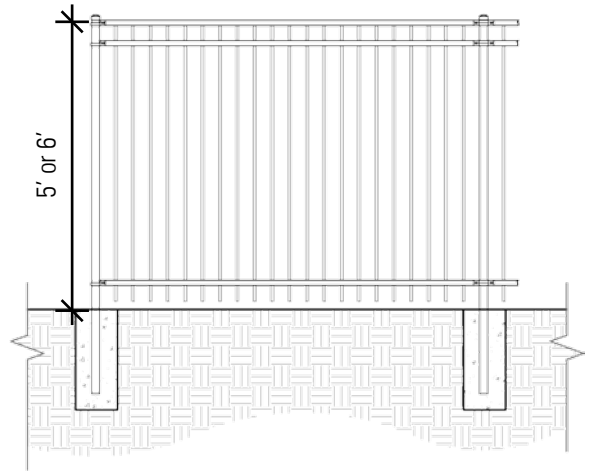

Type 'B' Fence

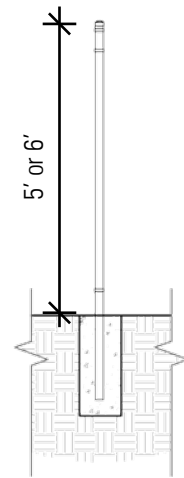

Type 'B' Fence Cross Section

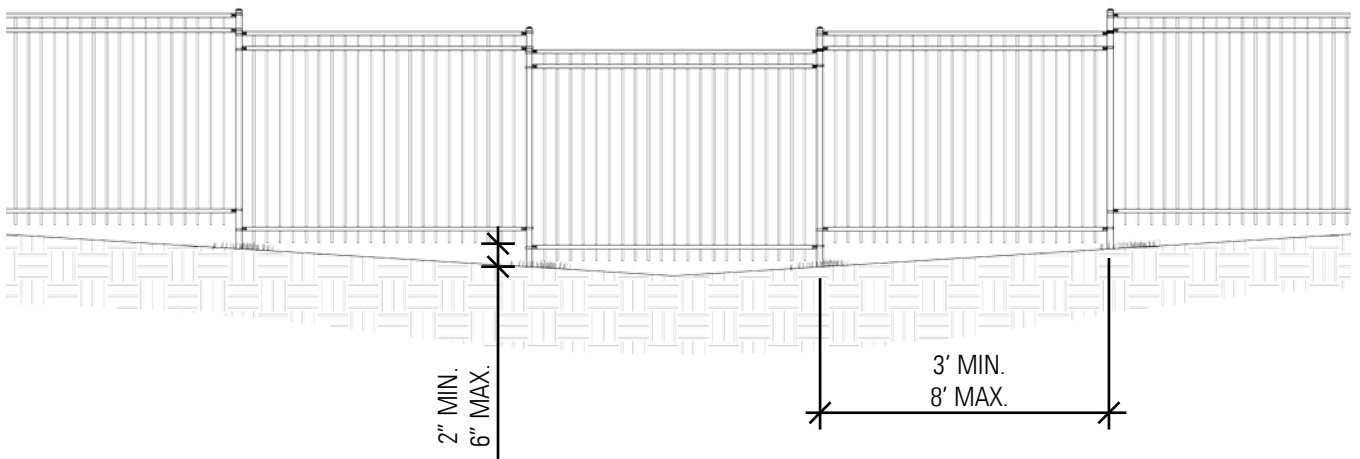

Fence at Slopped Sites

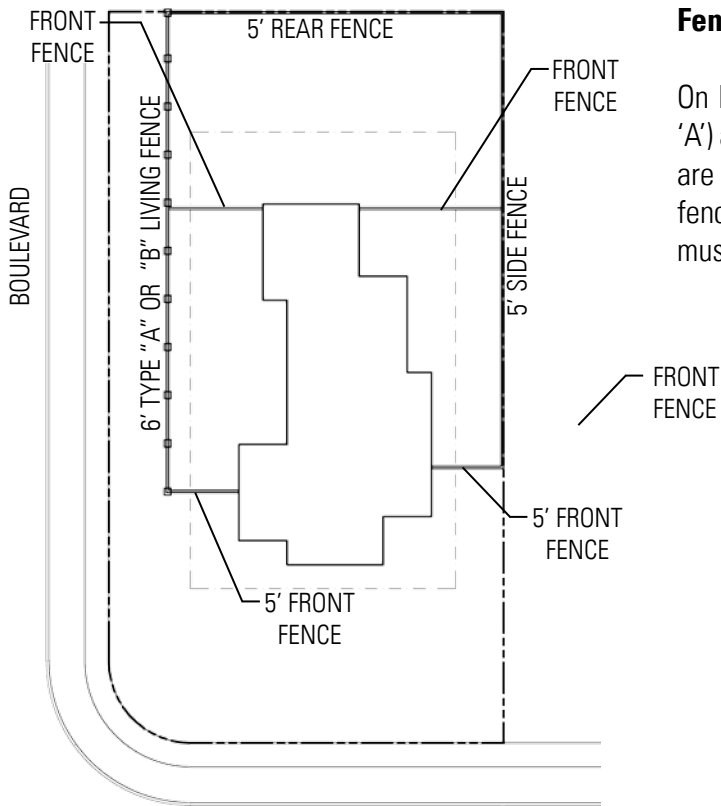

### Fence on Lots Along Boulevards

On lots adjacent to boulevards, 6' masonry fences (Type 'A') and 6' steel picket living fences (Type 'B' Living Fence) are required along that property line. All other back yard fences (other than the 6' side fence along the boulevard) must be 5' tall. Double gates are not allowed.

Fence along Boulevard

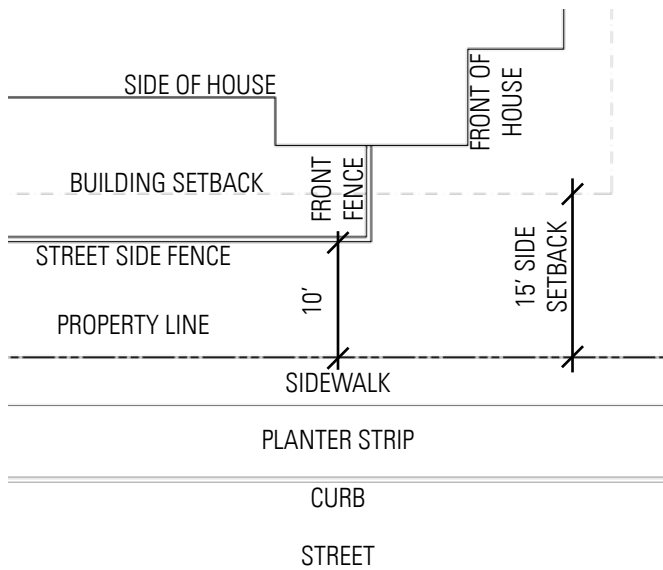

Side Street Fence Distances





Fence Type "A"



Fence Type "A"



Fence Type "B"



Fence Type "B"



Fence Type "A" and "B" Corner

## Full Screening Plants

Type 'B' Living Fences are highly encouraged for back yard fencing on all residential lots, but are not required. Please see the list of screening plants on page 28. However, builders must provide full screening plants prior to the builder closing on the sale of the home to the home buyer, in the following circumstances:

1. Builders are required to provide full screening plants if the back yard of a home can be seen from any street, including the situations listed below. In order to prevent the back yard from being seen from the street, such full screening plants must be on the Approved Plant List and be installed by the builder before the builder closes on the sale of the home to the home buyer. Screening plants must be at least 24 inches tall at installation and full screening must be achieved within 24 months of the builder closing on the sale of the home to the home buyer. Type 'B' Living Fence Option 6 cannot be used by the Builders.
  - a. If the home is located on a corner lot, the builder must install full screening plants along the street side portion of the backyard to prevent viewing the backyard from the street. The screening plants must be planted parallel to the side yard sidewalk and must be setback a minimum of five feet (5') and a maximum of ten feet (10') from the sidewalk. If a side yard fence is also built along the side yard sidewalk, the full screening plants must be planted inside the fence; and
  - b. If the home is located on a corner lot and the developer has installed a Type 'B' Fence along or adjacent to a boulevard, the builder must install the full screening plants only inside the fence, since the developer is responsible for the installation of the Type 'B' Fence.
2. The HOA can require the installation of full screening plants if in the opinion of the HOA, a homeowner does not maintain a tidy back yard or if unsightly views can be seen from the street. If full screening is required:
  - a. Full screening must be achieved within 24 months after the full screening plants are installed; and
  - b. Screening plants must be on the Approved Plant List.



**Type 'B' Living Fence Option 1**

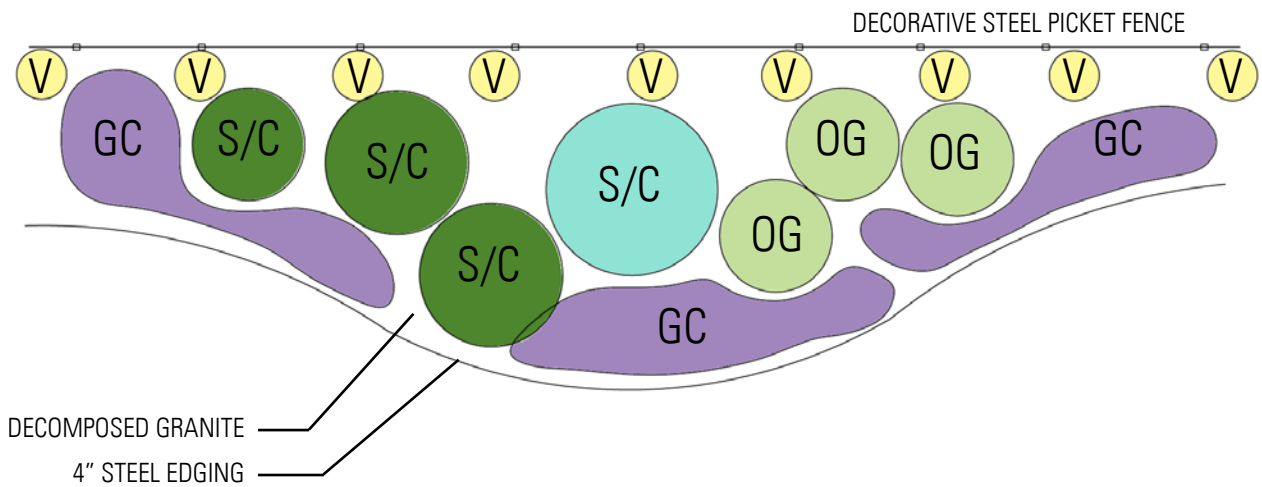

V	VINES
GC	GROUNDCOVER
S/C	SUCCULENT/ CACTUS
OG	ORNAMENTAL GRASSES

\*Reference Plant List for approved plant species

**Type 'B' Living Fence Option 2**

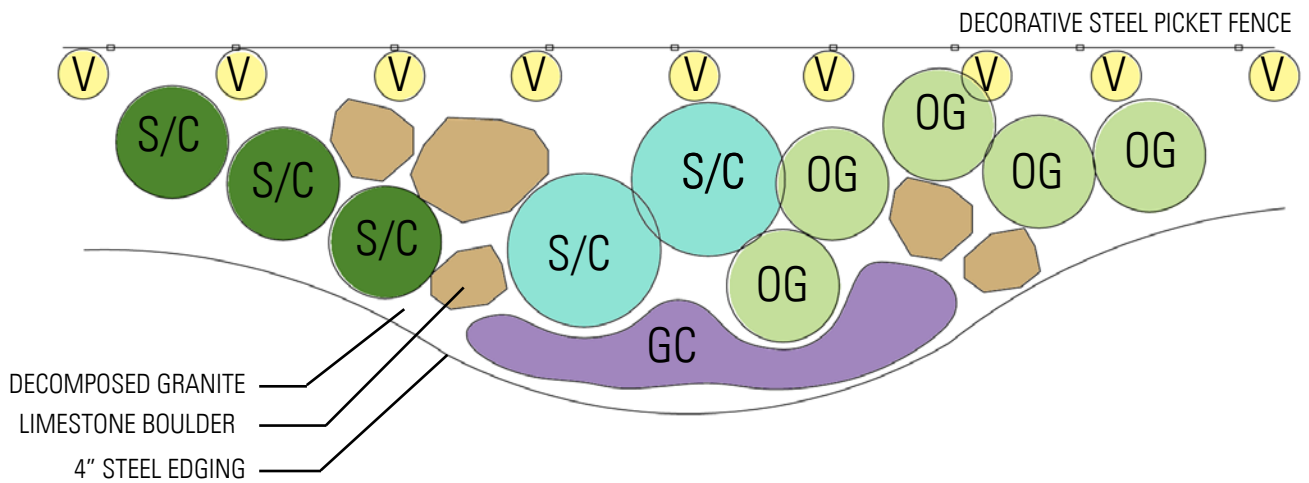

V	VINES
GC	GROUNDCOVER
S/C	SUCCULENT/ CACTUS
OG	ORNAMENTAL GRASSES

\*Reference Plant List for approved plant species



### Type 'B' Living Fence Option 3

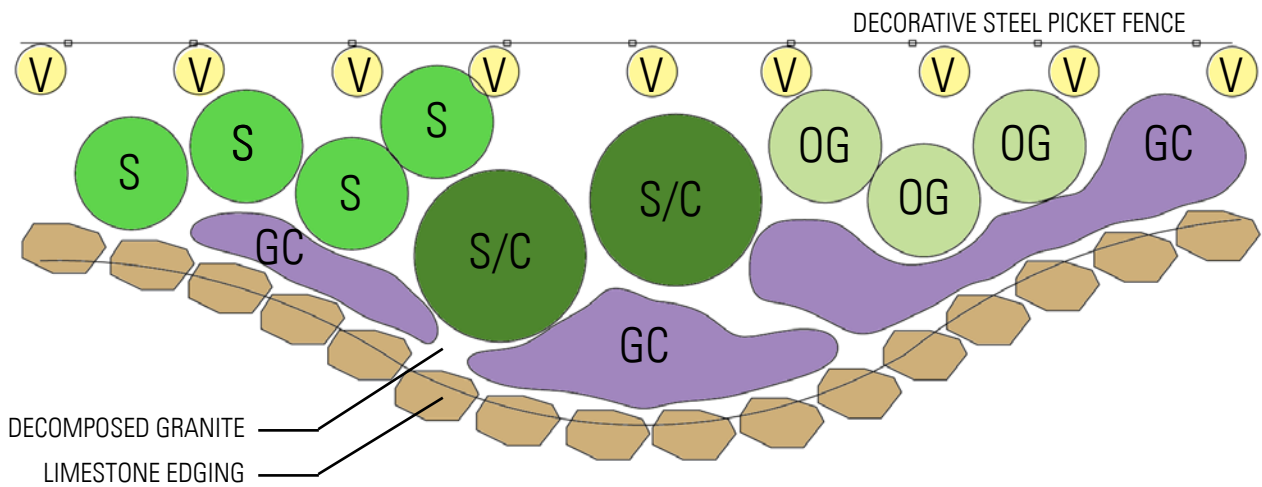

OT	ORNAMENTAL TREES
S	SHRUBS
V	VINES
GC	GROUNDCOVER
S/C	SUCCULENT/ CACTUS
OG	ORNAMENTAL GRASSES

\*Reference Plant List for approved plant species

## Type 'B' Living Fence Option 4

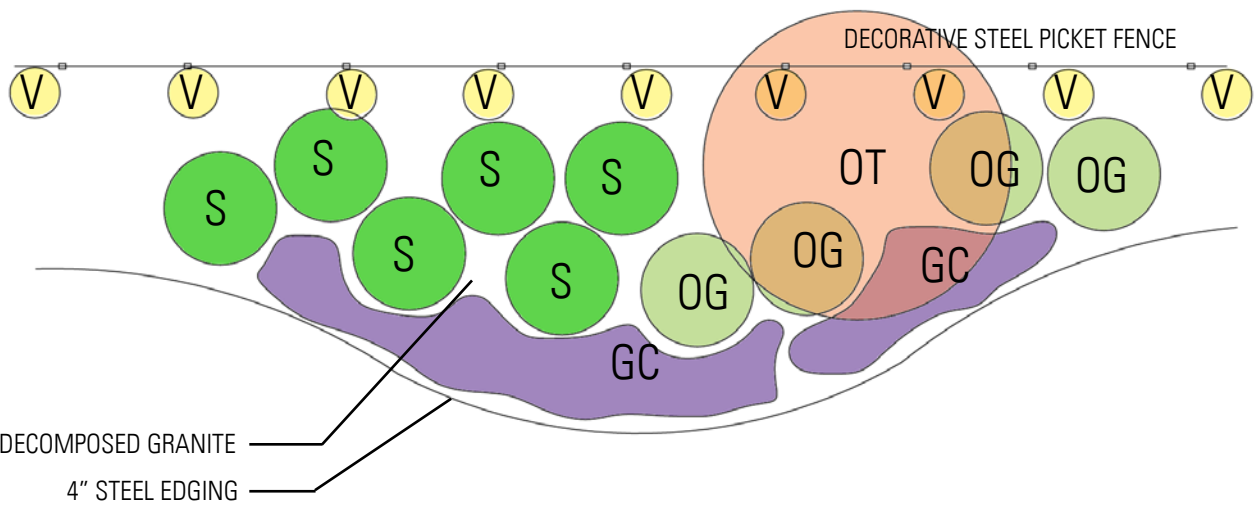

OT	ORNAMENTAL TREES
S	SHRUBS
V	VINES
GC	GROUNDCOVER
S/C	SUCCULENT/ CACTUS
OG	ORNAMENTAL GRASSES

\*Reference Plant List for approved plant species



## Type 'B' Living Fence Option 5

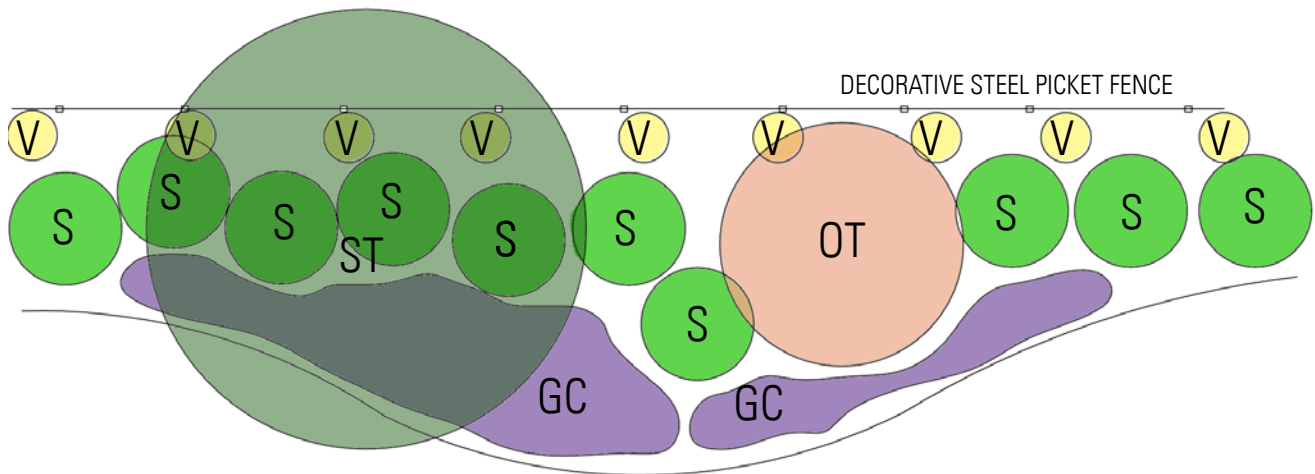

ST	SHADE TREES
OT	ORNAMENTAL TREES
S	SHRUBS
V	VINES
GC	GROUNDCOVER
S/C	SUCCULENT/ CACTUS
OG	ORNAMENTAL GRASSES

\*Reference Plant List for approved plant species



**Type 'B' Living Fence Option 6**

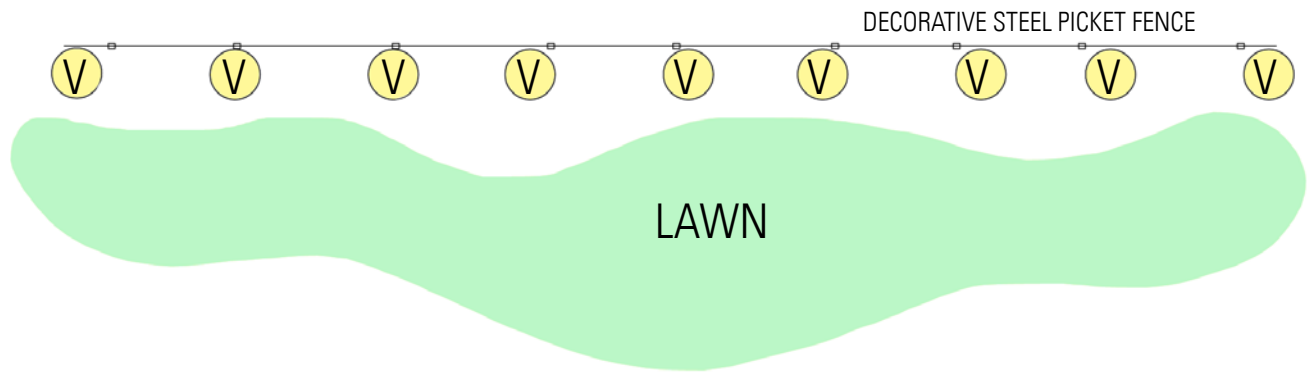

ST	SHADE TREES
OT	ORNAMENTAL TREES
S	SHRUBS
V	VINES
GC	GROUNDCOVER
S/C	SUCCULENT/ CACTUS
OG	ORNAMENTAL GRASSES

\*Reference Plant List for approved plant species

# ARCHITECTURAL ELEMENTS AND EXTERNAL DECORATIONS

## General

The intent of this section is to establish basic design criteria for the construction of architectural elements and structures within Esperanza. Emphasis is to be placed on the quality of material, design and construction in order to promote well-crafted structures within the community. These guidelines allow for diversity in design and should produce a climate of individuality, while insuring the architectural integrity of the community as a whole.

Esperanza neighborhoods are designed to promote “street scenes” that are aesthetically pleasing in character and reflect the feeling of a community. Developing a “street scene” requires builders to coordinate their architectural designs, as well as landscaping styles, in a manner that displays individuality, while maintaining a certain level of continuity throughout the development. The purpose of this section is to identify those elements that will influence the overall neighborhood appearance and street character.

## Exterior Site Lighting/Light Pollution/Dark Sky Lighting

Lighting on individual lots shall be installed in a manner which does not cause distraction, nuisance, or become unsightly. Light sources should not conflict with the sight lines of pedestrians or motorists in a manner that endangers their safety and welfare. Light sources must not “spill over” into neighboring yards or be visible from public view.

Exterior illumination of architectural features such as columns, entries, and landscape features are encouraged. Lights should be directed to illuminate address graphics. A sconce type light is preferred for this purpose.

Ground lighting or decorative fixtures must be of high quality materials and workmanship and be in scale and style with the residence.

Colored lenses, colored light bulbs, and fluorescent (except compact fluorescent) and neon lighting are not permissible. Incandescent, low voltage incandescent, metal halide, quartz, and natural gas lights are acceptable. All wiring for exterior lighting should be underground. See the CC&Rs, Section 3.47.

## External Decorations

Sculpture, flags and other external decorations along the streets shall be located behind the building set back line and subject to ACC review and approval. Seasonal decorations are encouraged and may be displayed at appropriate times. Removal of seasonal decorations is to occur within thirty (30) days following the specified holiday. See the CC&Rs, Section 3.43 for Christmas/holiday lighting requirements.

## Non Building Structures

All structures on the site including open air structures, furniture, play structures, and art work are to follow the intent and detail of these Guidelines and the CC&Rs, and to match or blend with the forms, materials, and colors of the main structures on the Lot.

Garbage enclosure and mechanical equipment must be completely screened and, as appropriate, made inaccessible to wildlife, by using architectural features integrated into the building design and/or the site walls' form, materials, and colors.

## Signage

All signs shall comply with City of Boerne requirements. All signage must be approved by the ACC in writing prior to installation and shall include signage required by code and other safety signage, directional signs, retail tenant identification, ACC identification signage and signage identifying individual buildings.

The Developer has the right to install project marketing signage within the community in an effort to enhance the image and marketability of property within Esperanza.

Builder informational/directional sign systems shall be coordinated with the developer, approved by the ACC and should reinforce the Esperanza theme. Signage should be consistent with the character of the surrounding area and adjacent architecture in terms of scale, color, materials and lighting levels. Signs must be clear and easy to read, and should complement the natural landscape in which they appear.

Signage shall not have exposed wiring, conduits, tubing, lamp ballast boxes or raceways. All cabinets, transformers, ballasts, attachment devices and similar equipment shall be concealed.

Builder "bandit" signs are not permitted.

Also see the CC&R's, Section 3.23

## Address Markers

Address markers must conform to the specifications provided herein. Address markers containing the street address must be clearly indicated on the front of the house, and illuminated. The size of the address numbers and colors must conform to the approved specifications as shown on right. Contact Kelly Atkin at 512.690.4322 for name and contact information for vendors. If the Owner wishes to install the address marker in a location other than on the front of the house, the Owner must submit a proposal to the ACC for review. Homes which are setback 40' or more from the street or the joint access drive, will be required to have an address monument installed at the street or access drive. Such address monument must conform to the approved specifications provided herein. Placement of the address monument sign must be such that it is illuminated, or additional lighting is added to illuminate the address sign, it must complement the main structure, and have address numbers that meet the approved specifications. Also, see the CC&Rs, Section 3.53.

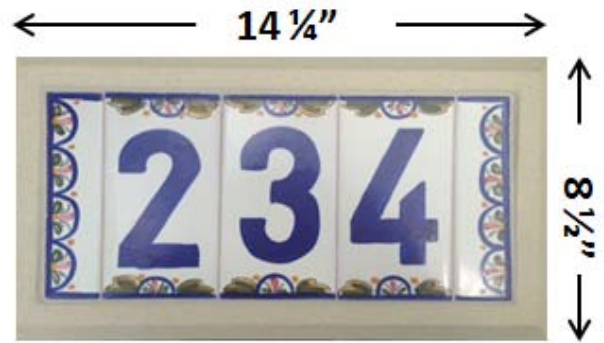

Address Block



Address Tile

## Mailboxes

As required by the Post Office, mailbox pavilions have been provided throughout the Community for mail pick-up and delivery. Contact the local post office regarding box assignment and key pick-up. Also, see the CC&Rs, Section 3.50.

## Paths, Outdoor Stairs and Terraces

These are to be designed to blend with the natural topography and vegetation, and with retaining walls, fences, or building foundations, and must be approved by the ACC. Materials are to be native stone, decomposed granite, gravel, concrete and/or wood, as approved by the ACC.

## Retaining Walls

Retaining walls should be used to minimize disturbance of the site and to integrate new improvements into the existing topography. All retaining walls must be approved by the ACC.





Wall height is limited to 4' constructed of limestone. Walls are to be stepped back or terraced, providing ample planting pockets. The terrace width is to be equal to the height of the wall below.

Higher walls may be permitted by ACC if resulting in lesser impacts. However, no wall may exceed 8' in height. All walls over four feet in height are to be designed by licensed professional engineer in the State of Texas.

All walls will be constructed of native limestone with a "dry stack appearance" and designed with a batter of approximately 2:12. These walls are to be backed up by concrete when necessary and are to be used to reduce grading impacts and disturbances of land and trees. While "dry stack appearance" walls are preferred, native limestone walls with visible mortar joints are also allowed. All mortar joints must be white; gray mortar joints are strictly prohibited.

Alternate wall materials may be approved by the ACC where such walls are not visible from adjacent or nearby home sites, roads or common amenities.

Tops and end of walls are to be shaped to blend into the adjoining natural contours. Also see the CC&Rs Section 3.54.

### **Outdoor Fireplaces and Barbecue Pits**

Outdoor fireplaces and barbecue pits shall be finished with native stone that blends with that on the main house structure.

Unless otherwise approved, fireplaces and pits shall be located in the side or rear yards only, within the side yard setback established for the house and not closer than fifteen (15) feet to any rear yard. They may not encroach any easement or alter the surface drainage on the lot.

These structures should be in scale with and integrated into the design of the house structure, deck and/or landscape areas and shall be sited in consideration of neighboring properties.

The Maximum height, excluding chimneys, shall not exceed six (6) feet. Height of the chimney shall be as required for operation and code compliance.

Retaining Wall Types





*Esperanza*

BOERNE ★ TEXAS  
PHASES 2A, 2B, 2D & 2E



## EXHIBIT B

### TABLE OF LANDSCAPE DESIGN STANDARDS AND GUIDELINES

**After recording, please return to:**

James D. Plasek  
Lookout Development Group, L.P.  
1789 S. Bagdad Road  
Suite 104  
Leander, Texas 78641  
Texas 78641

File Server:CLIENTS:Esperanza (Lookout):Rule Restatement Sept 2015:RulesRegulations9-15.doc

**Esperanza Community Association, Inc.**

**Table of Landscape Design Standards and Guidelines**

<b>Item #</b>	<b>Title of Document</b>	<b>Subdivision Name</b>	<b>Document No.</b>	<b>County</b>	<b>Recording Date</b>	<b>Vol/Page</b>
1	LANDSCAPE DESIGN STANDARDS AND GUIDELINES ESPERANZA COMMUNITY ASSOCIATION, INC. (replaced by item #2 below)	ESPERANZA, PHASE 1	00291229	KENDALL	3/20/2015	1459/25
2	AMENDED AND RESTATED LANDSCAPE DESIGN STANDARDS AND GUIDELINES ESPERANZA COMMUNITY ASSOCIATION, INC. September 2015 (replaced by #7 below)	ESPERANZA, PHASE 1	00296538	KENDALL	10/6/2015	1491/1
3	AMENDMENT OF LANDSCAPE DESIGN STANDARDS AND GUIDELINES ESPERANZA COMMUNITY ASSOCIATION, INC. June 2016 (the standards included in this amendment were included in item 7 below)	ESPERANZA, PHASE 1	00303102	KENDALL	6/29/2016	1529/193
4	SECOND AMENDMENT OF LANDSCAPE DESIGN STANDARDS AND GUIDELINES OF ESPERANZA COMMUNITY ASSOCIATION, INC. July 2016 (the standards included in this amendment were included in item 7 below)	ESPERANZA, PHASE 1	00303695	KENDALL	7/20/2016	1532/850
5	THIRD AMENDMENT OF LANDSCAPE DESIGN STANDARDS AND GUIDELINES OF ESPERANZA COMMUNITY ASSOCIATION, INC. October 2016 (the standards included in this amendment were included in item 7 below)	ESPERANZA, PHASE 1	00306308	KENDALL	10/26/2016	1548/289
6	FOURTH AMENDMENT OF LANDSCAPE DESIGN STANDARDS AND GUIDELINES OF ESPERANZA COMMUNITY ASSOCIATION, INC. November 2016 (the standards included in this amendment were included in item 7 below)	ESPERANZA, PHASE 1	00307243	KENDALL	11/30/2016	1553/1123
7	LANDSCAPE DESIGN STANDARDS AND GUIDELINES ESPERANZA COMMUNITY ASSOCIATION, INC. February 2019 (these landscape design standards incorporated all of the standards addressed in items 3 - 6 above). (replaced by #10 below)	ESPERANZA, PHASE 1	00328301	KENDALL	2/15/2019	1676/742
8	LANDSCAPE DESIGN STANDARDS AND GUIDELINES ESPERANZA COMMUNITY ASSOCIATION, INC. (replaced by item #10 below)	ESPERANZA (1.787 Acres)	00311831	KENDALL	5/15/2017	1580/417
9	LANDSCAPE DESIGN STANDARDS AND GUIDELINES ESPERANZA COMMUNITY ASSOCIATION, INC. February 2019 (replaced by item #10 below)	ESPERANZA, PHASE 1B	00331488	KENDALL	6/6/2019	1694/1059
10	AMENDED AND RESTATED LANDSCAPE DESIGN STANDARDS AND GUIDELINES OF ESPERANZA COMMUNITY ASSOCIATION, INC. September 2019 (replaced by #_ below)	ESPERANZA, PHASE 1, PHASE 1B AND 1.787 ACRE TRACT	00334486	KENDALL	9/13/2019	1713/964
11	LANDSCAPE DESIGN STANDARDS AND GUIDELINES ESPERANZA COMMUNITY ASSOCIATION, INC. January 2017 (replaced by item #12 below)	ESPERANZA, PHASE 2A	00308680	KENDALL	1/25/2017	1562/727
12	LANDSCAPE DESIGN STANDARDS AND GUIDELINES ESPERANZA COMMUNITY ASSOCIATION, INC. February 2019 (replaced by item #15 below)	ESPERANZA, PHASE 2A	00328356	KENDALL	2/19/2019	1677/6

**Esperanza Community Association, Inc.**

**Table of Landscape Design Standards and Guidelines**

<b>Item #</b>	<b>Title of Document</b>	<b>Subdivision Name</b>	<b>Document No.</b>	<b>County</b>	<b>Recording Date</b>	<b>Vol/Page</b>
13	LANDSCAPE DESIGN STANDARDS AND GUIDELINES ESPERANZA COMMUNITY ASSOCIATION, INC. February 2019 (replaced by item #15 below)	ESPERANZA, PHASE 2B	00328357	KENDALL	2/19/2019	1677/65
14	LANDSCAPE DESIGN STANDARDS AND GUIDELINES ESPERANZA COMMUNITY ASSOCIATION, INC. February 2019 (replaced by item #15 below)	ESPERANZA PHASE 2D	00328358	KENDALL	2/19/2019	1677/124
15	AMENDED AND RESTATED LANDSCAPE DESIGN STANDARDS AND GUIDELINES OF ESPERANZA COMMUNITY ASSOCIATION, INC. FOR ESPERANZA PHASE 2A, PHASE 2B AND PHASE 2D September 2019 (replaced by #16 below)	ESPERANZA, PHASE 2A, PHASE 2B AND PHASE 2D	00334488	KENDALL	9/13/2019	1713/1044
16	LANDSCAPE DESIGN STANDARDS AND GUIDELINES OF ESPERANZA COMMUNITY ASSOCIATION, INC. FOR ESPERANZA PHASE 2C April 2020	ESPERANZA PHASE 2C	00341945	KENDALL	5/18/2020	1761/667
17	LANDSCAPE DESIGN STANDARDS AND GUIDELINES OF ESPERANZA COMMUNITY ASSOCIATION, INC. FOR ESPERANZA PHASE 1C April 2020	ESPERANZA PHASE 1C	00341949	KENDALL	5/18/2020	1761/750
18	AMENDED AND RESTATED LANDSCAPE DESIGN STANDARDS AND GUIDELINES OF ESPERANZA COMMUNITY ASSOCIATION, INC. FOR ESPERANZA PHASE 2A, PHASE 2B, PHASE 2D AND PHASE 2E April 2020	ESPERANZA PHASE 2A, PHASE 2B, PHASE 2D AND PHASE 2E	00341976	KENDALL	5/19/2020	1762/1
19	LANDSCAPE DESIGN STANDARDS AND GUIDELINES OF THE ESPERANZA COMMUNITY ASSOCIATION, INC. THE VILLAGE OF BRAVADA (A PART OF ESPERANZA PHASE 2F) September 2021	VILLAGE OF BRAVADA (A PART OF ESPERANZA PHASE 2F)	see applicable cover page for document #	KENDALL	see applicable cover page for recording date	see applicable cover page for Vol/Page #

**Kendall County  
Darlene Herrin  
Kendall County  
Clerk**

---

**Instrument Number:** 361558

eRecording - Real Property

RESTRICTIONS

Recorded On: September 17, 2021 09:04 AM

Number of Pages: 61

---

**" Examined and Charged as Follows: "**

Total Recording: \$262.00

---

**\*\*\*\*\* THIS PAGE IS PART OF THE INSTRUMENT \*\*\*\*\***

Any provision herein which restricts the Sale, Rental or use of the described REAL PROPERTY because of color or race is invalid and unenforceable under federal law.

**File Information:**

Document Number: 361558  
Receipt Number: 20210917000012  
Recorded Date/Time: September 17, 2021 09:04 AM  
User: Paula P  
Station: cclerk06

**Record and Return To:**

ERECORDING PARTNERS  
101 W NUEVA  
  
SAN ANTONIO TX

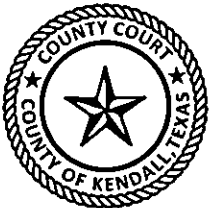

**STATE OF TEXAS  
COUNTY OF**

**I hereby certify that this Instrument was FILED In the File Number sequence on the date/time printed hereon, and was duly RECORDED in the Official Records of Kendall County, Texas.**

Darlene Herrin  
Kendall County Clerk  
Kendall County, TX

*Darlene Herrin*